



UNITED ARAB EMIRATES  
MINISTRY OF EDUCATION  
ASSESSMENT DEPARTMENT

# PISA RELEASED ITEMS MATHEMATICS

## PISA 2012



## Table of Contents

M037: Farms .....	3
M047: Lichen.....	5
M124: Walking .....	8
M136: Apples .....	11
M143: Coins .....	15
M143: Cubes.....	16
M148: Continent Area .....	18
M150: Growing Up .....	21
M154: Pizzas.....	25
M158: Shapes .....	26
M159: Speed of Racing Car.....	29
M161: Triangles .....	32
M179: Robberies.....	34
M215: Braking .....	36
M266: Carpenter .....	39
M267: Patio .....	41
M307: Drug Concentrations .....	43
M309: Building Blocks.....	46
M402: Internet Relay Chat .....	49
M413: Exchange Rate.....	51
M432: Reaction Time .....	53
M438: Exports .....	56
M465: Water Tank.....	58
M467: Coloured Candies .....	60
M468: Science Tests.....	61
M471: Spring Fair.....	62
M472: Swing .....	63
M479: Student Heights.....	65
M480: Payments by Area.....	66
M484: Bookshelves.....	68
M505: Litter .....	69
M509: Earthquake.....	70
M510: Choices .....	71
M513: Test Scores .....	72
M515: Shoes for Kids.....	74
M520: Skateboard.....	75
M521: Table Tennis Tournament.....	78
M523: Lighthouse.....	80
M525: Decreasing CO <sub>2</sub> Levels.....	83
M535: Twisted Building .....	86
M537: Heartbeat .....	90
M543: Space Flight .....	92
M547: Staircase .....	93
M552: Rock Concert .....	94
M555: Number Cubes .....	95
M702: Support for the President .....	96
M703: Moving Walkways .....	98
M704: The Best Car .....	100
M806: Step Pattern .....	102
M836: Postal Charges.....	103
Source Publications for Released Items .....	105

## M037: Farms

---

Here you see a photograph of a farmhouse with a roof in the shape of a pyramid.



Below is a student's mathematical model of the farmhouse **roof** with measurements added.

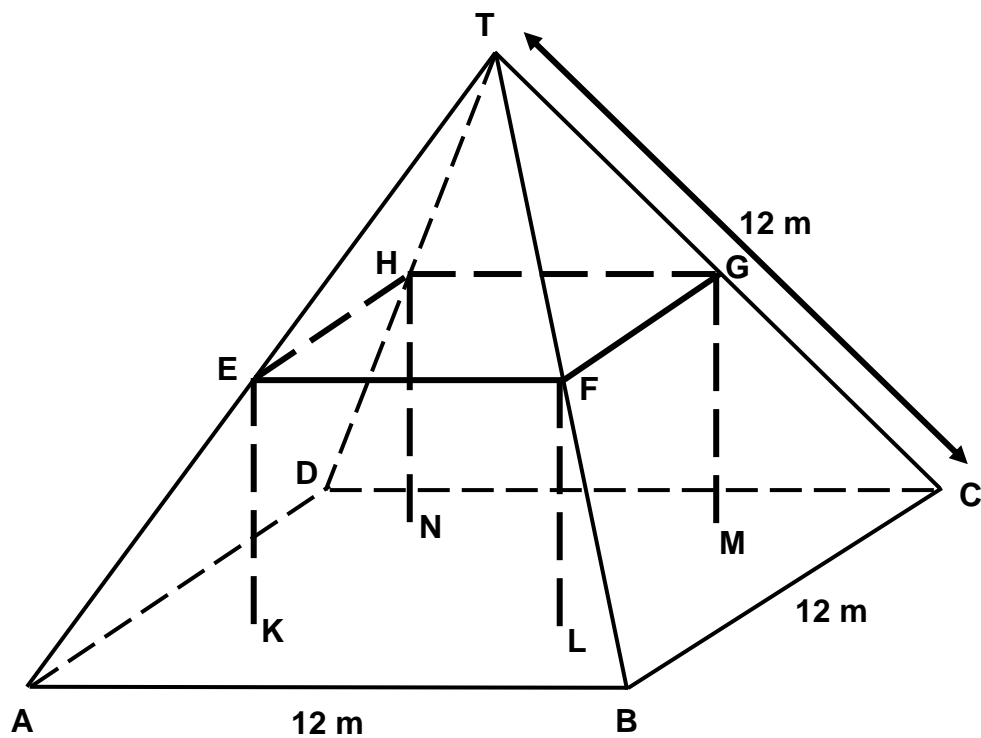

The attic floor, ABCD in the model, is a square. The beams that support the roof are the edges of a block (rectangular prism) EFGHLMN. E is the middle of AT, F is the middle of BT, G is the middle of CT and H is the middle of DT. All the edges of the pyramid in the model have length 12 m.

---

**Question 1: FARMS***M037Q01*

Calculate the area of the attic floor ABCD.

The area of the attic floor ABCD = \_\_\_\_\_ m<sup>2</sup>

**FARMS SCORING 1*****Full credit***

Code 1: 144 (unit already given)

***No credit***

Code 0: Other responses.

Code 9: Missing.

---

**Question 2: FARMS***M037Q02*

Calculate the length of EF, one of the horizontal edges of the block.

The length of EF = \_\_\_\_\_ m

**FARMS SCORING 2*****Full credit***

Code 1: 6 (unit already given)

***No credit***

Code 0: Other responses.

Code 9: Missing.

## M047: Lichen

---

A result of global warming is that the ice of some glaciers is melting. Twelve years after the ice disappears, tiny plants, called lichen, start to grow on the rocks.

Each lichen grows approximately in the shape of a circle.

The relationship between the diameter of this circle and the age of the lichen can be approximated with the formula:

$$d = 7.0 \times \sqrt{(t - 12)} \quad \text{for } t \geq 12$$

where  $d$  represents the diameter of the lichen in millimetres, and  $t$  represents the number of years after the ice has disappeared.

---

### Question 1: LICHEN

M047Q01- 0 1 8 9

Using the formula, calculate the diameter of the lichen, 16 years after the ice disappeared.

Show your calculation.

#### LICHEN SCORING 1

QUESTION INTENT: To elicit student's ability to apply a given formula.

#### **Full credit**

Code 2: 14mm (units not required). Code 2 should be given as long as the correct answer is 14 whether working out is shown or not.

#### **Partial credit**

Code 1: Partial responses including:

- Correct substitution of value in the formula but incorrect answer Or missing answer.
- Incomplete answers (eg,  $7\sqrt{4}$ ).

#### **No credit**

Code 0: Other responses.

Code 9: Missing.

#### **Example responses**

Code 2:

$$d = 7.0 \times \sqrt{16 - 12} \qquad 14\text{mm} \qquad 14$$
$$d = 14$$

$$d = 7.0 \times \sqrt{16 - 12} \quad (\text{Note that here the calculations are all correct, but the unit is wrong. We will assume for now that it is the slip of the pen})$$

$$d = 7.0 \times \sqrt{4}$$

$$d = 14 \text{ years}$$

Code 1:

$$d = 7.0 \times \sqrt{16 - 12} \quad (\text{wrong answer but correct substitution})$$

$$d = 16$$

$$d = 7.0 \times \sqrt{16 - 12} \quad (\text{incomplete answer})$$

$$d = 7\sqrt{4}$$

Code 0:

16

## Question 2: LICHEN

M047Q02- 0 1 2 8 9

Ann measured the diameter of some lichen and found it was 35 millimetres.

How many years ago did the ice disappear at this spot?

Show your calculation.

### LICHEN SCORING 2

QUESTION INTENT: To elicit student's ability to apply a given formula.

#### **Full credit**

Code 2: 37 years (unit not required) whether working out is shown or not.

#### **Partial credit**

Code 1: Correct substitution of values in the formula but incorrect answer or missing answer.

OR

36 years or 38 years. (Students may arrive at these answers using the trial and error method)

#### **No credit**

Code 0: Other responses.

Code 9: Missing.

### Example responses

Code 2:

$$\begin{array}{ll} 35 = 7 \times \sqrt{t-12} & 35 \div 7 = 5 \\ 5 = \sqrt{t-12} & 7 \times 5 = 7 \times \sqrt{25} \\ 25 = t - 12 & = 7 \times \sqrt{25+12} \\ t = 37 & = 7 \times 37 \\ & \therefore 37 \text{ years} \end{array}$$

$$\begin{array}{ll} 35/7 = 5 & \text{(Strictly incorrect algebraic representation, but we know what the} \\ 5^2 = 25 & \text{student is trying to do)} \\ 25+12 = 37 & \end{array}$$

$$\begin{array}{ll} t = 15 \quad d = 12.1 & \\ t = 25 \quad d = 25.2 & \text{(Note that here the answer 37 is embedded in} \\ t = 40 \quad d = 37.0 & \text{an equation that is correct)} \\ t = 35 \quad d = 33.6 & \\ t = 37 \quad d = 35 & \end{array}$$

So 37 years after the ice disappeared

$$756 = 35 = 7X\sqrt{(37-12)} = 7X\sqrt{25} = 7X5 = 35$$

Code 1:

$$\begin{array}{lll} 35 = 7.0 \times \sqrt{t-12} & 35 = 7.0 \times \sqrt{t-12} & 35 = 7.0 \times \sqrt{t-12} \\ 35^2 = 7^2 \times t - 12 & 5 = \sqrt{t-12} & 5 = \sqrt{t-12} \\ 49t = 1237 & 25 = t^2 - 12^2 & 5 = \sqrt{t} - \sqrt{12} \\ t = 25 & t = 13 & \text{Too hard!} \end{array}$$

Code 0:

$$\begin{array}{l} 35 = 7.0 \times \sqrt{t-12} \\ 28 = \sqrt{t-12} \\ 784 = t - 12 \\ t = 796 \end{array}$$

40 years

## M124: Walking

---

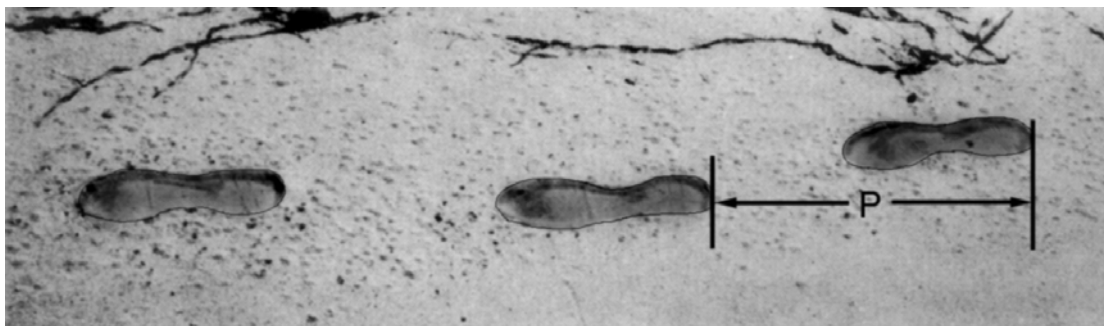

The picture shows the footprints of a man walking. The pacelength  $P$  is the distance between the rear of two consecutive footprints.

For men, the formula,  $\frac{n}{P} = 140$ , gives an approximate relationship between  $n$  and  $P$  where,

$n$  = number of steps per minute, and

$P$  = pacelength in metres.

---

### Question 1: WALKING

M124Q01- 0 1 2 9

If the formula applies to Heiko's walking and Heiko takes 70 steps per minute, what is Heiko's pacelength? Show your work.

#### WALKING SCORING 1

##### *Full credit*

Code 2:

0.5 m or 50 cm,  $\frac{1}{2}$  (unit not required)

$$\begin{aligned}70/p &= 140 \\70 &= 140 p \\p &= 0.5\end{aligned}$$

70/140

##### *Partial credit*

Code 1: Correct substitution of numbers in the formula, but incorrect answer, or no answer.

$$\frac{70}{p} = 140 \quad (\text{substitute numbers in the formula only})$$



$$\frac{70}{p} = 140 \quad (\text{correct substitution, but working out is incorrect})$$
$$70 = 140 p$$
$$p = 2$$

OR

Correctly manipulated the formula into  $P=n/140$ , but no further correct working.

**No credit**

Code 0: Other responses.

- 70 cm.

Code 9: Missing.

---

**Question 3: WALKING**

M124Q03- 00 11 21 22 23 24 31 99

Bernard knows his pacelength is 0.80 metres. The formula applies to Bernard's walking.

Calculate Bernard's walking speed in metres per minute and in kilometres per hour. Show your working out.

**WALKING SCORING 3**

**Full credit**

Code 31: Correct answers (unit not required) for both metres/minute and km/hour:

- $n = 140 \times .80 = 112$ .
- Per minute he walks  $112 \times .80$  metres = 89.6 metres.
- His speed is 89.6 metres per minute.
- So his speed is 5.38 or 5.4 km/hr.

Code 31 as long as both correct answers are given (89.6 and 5.4), whether working out is shown or not. Note that errors due to rounding are acceptable. For example, 90 metres per minute and 5.3 km/hr ( $89 \times 60$ ) are acceptable.

- 89.6, 5.4.
- 90, 5.376 km/h.
- 89.8, 5376 m/hour [note that if the second answer is given without units, it should be coded as 22].

**Partial credit (2-point)**

Code 21: As for code 31 but fails to multiply by 0.80 to convert from steps per minute to metres per minute. For example, his speed is 112 metres per minute and 6.72 km/hr.

- 112, 6.72 km/h.

Code 22: The speed in metres per minute correct (89.6 metres per minute) but conversion to kilometres per hour incorrect or missing.

- 89.6 metres/minute, 8960 km/hr.
- 89.6, 5376.
- 89.6, 53.76.
- 89.6, 0.087 km/h.
- 89.6, 1.49 km/h.

Code 23: Correct method (explicitly shown) with minor calculation error(s) not covered by Code 21 and Code 22. No answers correct.

- $n=140 \times .8 = 1120$ ;  $1120 \times 0.8 = 896$ . He walks 896 m/min, 53.76km/h.
- $n=140 \times .8 = 116$ ;  $116 \times 0.8 = 92.8$ . 92.8 m/min -> 5.57km/h.

Code 24: Only 5.4 km/hr is given, but not 89.6 metres/minute (intermediate calculations not shown).

- 5.4.
- 5.376 km/h.
- 5376 m/h.

***Partial credit (1-point)***

Code 11:  $n = 140 \times .80 = 112$ . No further working out is shown or incorrect working out from this point.

- 112.
- $n=112$ , 0.112 km/h.
- $n=112$ , 1120 km/h.
- 112 m/min, 504 km/h.

***No credit***

Code 00: Other responses.

Code 99: Missing.

## M136: Apples

A farmer plants apple trees in a square pattern. In order to protect the apple trees against the wind he plants conifer trees all around the orchard.

Here you see a diagram of this situation where you can see the pattern of apple trees and conifer trees for any number (n) of rows of apple trees:

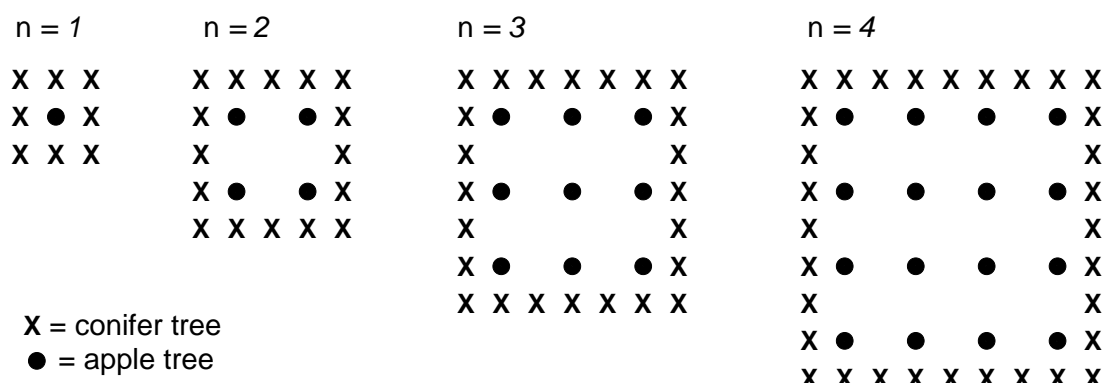

### Question 1: APPLES

M136Q01- 01 02 11 12 21 99

Complete the table:

n	Number of apple trees	Number of conifer trees
1	1	8
2	4	
3		
4		
5		

### APPLES SCORING 1

Complete the table:

n	Number of apple trees	Number of conifer trees
1	1	8
2	4	16
3	9	24
4	16	32
5	25	40

#### Full credit

Code 21: All 7 entries correct

#### Partial credit

[These codes are for ONE error/missing in the table. Code 11 is for ONE error for n=5, and Code 12 is for ONE error for n=2 or 3 or 4]

Code 11: Correct entries for n=2,3,4, but ONE cell for n=5 incorrect or missing

- The last entry '40' is incorrect; everything else is correct.
- '25' incorrect; everything else is correct.

Code 12: The numbers for n=5 are correct, but there is ONE error /missing for n=2 or 3 or 4.

**No credit**

*[These codes are for TWO or more errors]*

Code 01: Correct entries for n=2,3,4, but BOTH cells for n=5 incorrect

- Both '25' and '40' are incorrect; everything else is correct.

Code 02: Other responses.

Code 99: Missing.

---

**Question 2: APPLES**

M136Q02- 00 11 12 13 14 15 99

There are two formulae you can use to calculate the number of apple trees and the number of conifer trees for the pattern described above:

$$\text{Number of apple trees} = n^2$$

$$\text{Number of conifer trees} = 8n$$

where  $n$  is the number of rows of apple trees.

There is a value of  $n$  for which the number of apple trees equals the number of conifer trees. Find the value of  $n$  and show your method of calculating this.

.....

.....

.....

.....

**APPLES SCORING 2**

**Full credit**

*[These codes are for responses with the correct answer, n=8, using different approaches]*

Code 11: n=8, algebraic method explicitly shown

- $n^2 = 8n$ ,  $n^2 - 8n = 0$ ,  $n(n - 8) = 0$ ,  $n = 0$  &  $n = 8$ , so  $n = 8$

Code 12: n=8, no clear algebra presented, or no work shown

- $n^2 = 8^2 = 64$ ,  $8n = 8 \cdot 8 = 64$

- $n^2 = 8n$ . This gives  $n=8$ .
- $8 \times 8 = 64$ ,  $n=8$
- $n = 8$
- $8 \times 8 = 8^2$

Code 13:  $n=8$ , using other methods, e.g., using pattern expansion or drawing.

*[These codes are for responses with the correct answer,  $n=8$ , PLUS the answer  $n=0$ , with different approaches.]*

Code 14: As for Code 11 (clear algebra), but gives both answers  $n=8$  AND  $n=0$

- $n^2 = 8n$ ,  $n^2 - 8n = 0$ ,  $n(n - 8)=0$ ,  $n = 0$  &  $n = 8$

Code 15: As for Code 12 (no clear algebra), but gives both answers  $n=8$  AND  $n=0$

**No credit**

Code 00: Other responses, including just the response  $n=0$ .

- $n^2 = 8n$  (a repeat of the statement from the question)
- $n^2 = 8$
- $n=0$ . You can't have the same number, because for every apple tree, there are 8 conifer trees.

Code 99: Missing.

**Question 3: APPLES**

M136Q03- 01 02 11 21 99

Suppose the farmer wants to make a much larger orchard with many rows of trees. As the farmer makes the orchard bigger, which will increase more quickly: the number of apple trees or the number of conifer trees? Explain how you found your answer.

.....

.....

**APPLES SCORING 3**

**Full credit**

Code 21: Correct response (apple trees) accompanied by a valid explanation. For example:

- Apple trees =  $n \times n$  and conifer trees =  $8 \times n$  both formulas have a factor  $n$ , but apple trees have another  $n$  which will get larger where the factor 8 stays the same. The number of apple trees increases more quickly.
- The number of apple trees increases faster because that number is being squared instead of multiplied by 8
- Number of apple trees is quadratic. Number of conifer trees is linear. So apple trees will increase faster.
- Response uses graph to demonstrate that  $n^2$  exceeds  $8n$  after  $n=8$ .

*[Note that code 21 is given if the student gives some algebraic explanations **based on the formulae  $n^2$  and  $8n$** .]*

**Partial credit**

Code 11: Correct response (apple trees) based on specific examples or based on extending the table.

- The number of apple trees will increase more quickly because, if we use the table (previous page), we find that the no. of apple trees increases faster than the no. of conifer trees. This happens especially after the no. of apple trees and the number of conifer trees are equivalent.
- The table shows that the number of apple trees increases faster.

OR

Correct response (apple trees) with SOME evidence that the relationship between  $n^2$  and  $8n$  is understood, but not so clearly expressed as in Code 21.

- Apple trees after  $n > 8$ .
- After 8 rows, the number of apple trees will increase more quickly than conifer trees.
- Conifer trees until you get to 8 rows, then there will be more apple trees.

**No credit**

Code 01: Correct response (apple trees) with no, insufficient or wrong explanation.

- Apple trees
- Apple trees because they are populating the inside which is bigger than just the perimeter.
- Apples trees because they are surrounded by conifer trees.

Code 02: Other responses.

- Conifer trees
- Conifer trees because for every additional row of apple trees, you need lots of conifer trees.
- Conifer trees. Because for every apple tree there are 8 conifer trees.
- I don't know.

Code 99: Missing.

## M143: Coins

---

You are asked to design a new set of coins. All coins will be circular and coloured silver, but of different diameters.

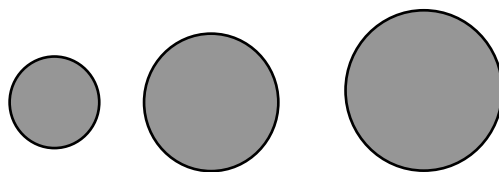

Researchers have found out that an ideal coin system meets the following requirements:

- diameters of coins should not be smaller than 15 mm and not be larger than 45 mm.
- given a coin, the diameter of the next coin must be at least 30% larger.
- the minting machinery can only produce coins with diameters of a whole number of millimetres (e.g. 17 mm is allowed, 17.3 mm is not).

---

### Question 1: COINS

M143Q01-0 1 8 9

You are asked to design a set of coins that satisfy the above requirements. You should start with a 15 mm coin and your set should contain as many coins as possible. What would be the diameters of the coins in your set?

#### COINS SCORING 1

QUESTION INTENT: Understanding and use of complicated information to do calculations.

Code 1: 15 – 20 – 26 – 34 – 45. It is possible that the response could be presented as actual drawings of the coins of the correct diameters. This should be coded as 1 as well.

Code 8: Gives a set of coins that satisfy the three criteria, but not the set that contains as many coins as possible, eg., 15 – 21 – 29 – 39, or 15 – 30 – 45  
OR  
The first three diameters correct, the last two incorrect (15 – 20 – 26 - )  
OR  
The first four diameters correct, the last one incorrect (15 – 20 – 26 – 34 - )

Code 0: Other responses.

Code 9 : Missing.

# M143: Cubes

## Question 1: CUBES

M145Q01

In this photograph you see six dice, labelled (a) to (f). For all dice there is a rule:  
The total number of dots on two opposite faces of each die is always seven.

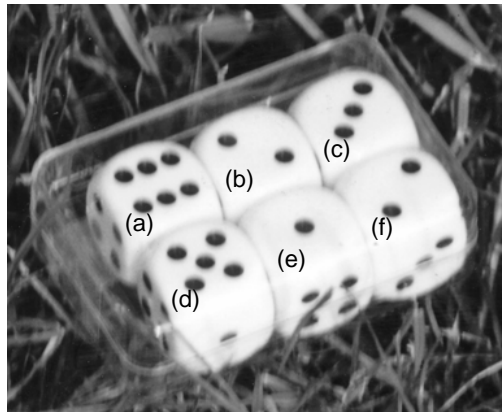

Write in each box the number of dots on the **bottom** face of the dice corresponding to the photograph.







(a)	(b)	(c)
(d)	(e)	(f)

### CUBES SCORING 1

#### *Full credit*

Code 1: Top row (1 5 4) Bottom Row (2 6 5). Equivalent answer shown as dice faces is also acceptable.

1	5	4
2	6	5



***No credit***

Code 0: Other responses.

Code 9: Missing.

## M148: Continent Area

---

*Below is a map of Antarctica.*



---

## Question 2: CONTINENT AREA

P01480

Estimate the area of Antarctica using the map scale.

Show your working out and explain how you made your estimate. (You can draw over the map if it helps you with your estimation)

### CONTINENT AREA SCORING 2

#### **Full credit**

*[These codes are for responses using the correct method AND getting the correct answer. The second digit indicates the different approaches]*

Code 21: Estimated by drawing a square or rectangle - between 12 000 000 sq kms and 18 000 000 sq kms (units not required)

Code 22: Estimated by drawing a circle - between 12 000 000 sq kms and 18 000 000 sq kms

Code 23: Estimated by adding areas of several regular geometric figures - between 12 000 000 and 18 000 000 sq kms

Code 24: Estimated by other correct method – between 12 000 000 sq kms and 18 000 000 sq kms

Code 25: Correct answer (between 12 000 000 sq kms and 18 000 000 sq kms ) but no working out is shown.

#### **Partial credit**

*[These codes are for responses using the correct method BUT getting incorrect or incomplete answer. The second digit indicates the different approaches, matching the second digit of the Full credit codes.]*

Code 11: Estimated by drawing a square or rectangle – correct method but incorrect answer or incomplete answer

- Draws a rectangle and multiplies width by length, but the answer is an over estimation or an under estimation (e.g., 18 200 000)
- Draws a rectangle and multiplies width by length, but the number of zeros are incorrect (e.g.,  $4000 \times 3500 = 140\,000$ )
- Draws a rectangle and multiplies width by length, but forgets to use the scale to convert to square kilometres (e.g.,  $12\text{cm} \times 15\text{cm} = 180$ )
- Draws a rectangle and states the area is  $4000\text{km} \times 3500\text{km}$ . No further working out.

Code 12: Estimated by drawing a circle – correct method but incorrect answer or incomplete answer

Code 13: Estimated by adding areas of several regular geometric figures – correct method but incorrect answer or incomplete answer

Code 14: Estimated by other correct method –but incorrect answer or incomplete answer

**No credit**

Code 01: Calculated the perimeter instead of area.

- E.g., 16 000 km as the scale of 1000km would go around the map 16 times.

Code 02: Other responses.

- E.g., 16 000 km (no working out is shown, and the answer is incorrect)

Code 99: Missing

**Summary table**

A summary table below shows the relationship between the codes:

Estimation method	Code		
	<b>FULL CREDIT –</b> Correct answer: between 12 000 000 and 18 000 000 sq kms	<b>PARTIAL CREDIT</b> – Correct method but incorrect or incomplete answer.	<b>No credit</b>
Drawing a rectangle	21	11	—
Drawing a circle	22	12	—
Adding regular shapes	23	13	—
Other correct methods	24	14	—
No working shown	25	—	—
Perimeter	—	—	01
Other incorrect responses	—	—	02
Missing	—	—	99

**NOTE:**

While coding this question, apart from reading what the student wrote in words in the space provided, make sure that you also look at the actual map to see what drawings/markings that the student has made on the map. Very often, the student does not explain very well in words exactly what he/she did, but you can get more clues from looking at the markings on the map itself. The aim is not to see if students can express well in words. The aim is to try to work out how the student arrived at his/her answer. Therefore, even if no explanation is given, but you can tell from the sketches on the map itself what the student did, or from the formulae the student used, please regard it as explanations given.

## M150: Growing Up

---

### YOUTH GROWS TALLER

In 1998 the average height of both young males and young females in the Netherlands is represented in this graph.

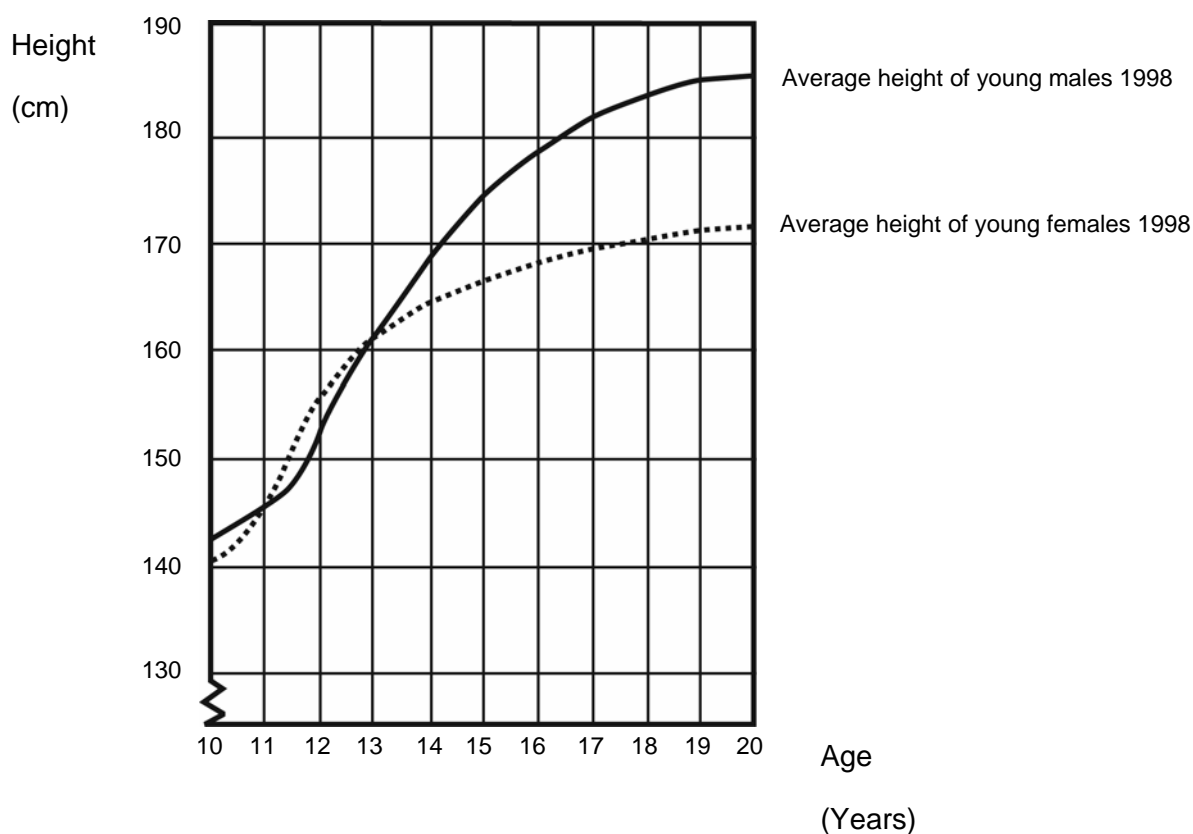

---

### Question 1: GROWING UP

M150Q01- 0 1 9

Since 1980 the average height of 20-year-old females has increased by 2.3 cm, to 170.6 cm. What was the average height of a 20-year-old female in 1980?

Answer: .....cm

### GROWING UP SCORING 1

#### **Full credit**

Code 1: 168.3 cm (unit already given).

#### **No credit**

Code 0: Other responses.

Code 9: Missing.

---

**Question 3: GROWING UP**

M150Q03- 01 02 11 12 13 99

Explain how the graph shows that on average the growth rate for girls slows down after 12 years of age.

.....

.....

.....

**GROWING UP SCORING 3**

***Full credit***

The key here is that the response should refer to the “change” of the gradient of the graph for female. This can be done explicitly or implicitly. Code 11 and code 12 are for explicitly mentioning about the steepness of the curve of the graph, while code 13 is for implicit comparison using the actual amount of growth before 12 years and after 12 years of age.

Code 11: Refers to the reduced steepness of the curve from 12 years onwards, using daily-life language, not mathematical language.

- It does no longer go straight up, it straightens out.
- The curve levels off.
- It is more flat after 12.
- The line of the girls starts to even out and the boys line just gets bigger.
- It straightens out and the boys graph keeps rising.

Code 12: Refers to the reduced steepness of the curve from 12 years onwards, using mathematical language.

- You can see the gradient is less.
- The rate of change of the graph decreases from 12 years on.
- [The student computed the angles of the curve with respect to the x-axis before and after 12 years.]

In general, if words like “gradient”, “slope”, or “rate of change” are used, regard it as using mathematical language.

Code 13: Comparing actual growth (comparison can be implicit).

- From 10 to 12 the growth is about 15 cm, but from 12 to 20 the growth is only about 17 cm.
- The average growth rate from 10 to 12 is about 7.5 cm per year, but about 2 cm per year from 12 to 20 years.

***No credit***

Code 01: Student indicates that female height drops below male height, but does NOT mention the steepness of the female graph or a comparison of the female growth rate before and after 12 years.

- The female line drops below the male line.

If the student mentions that the female graph becomes less steep, AS WELL AS the fact that the graph falls below the male graph, then full credit (Code 11, 12 or 13) should be given. We are not looking for a comparison between male and female graphs here, so ignore any reference on such a comparison, and make a judgement based on the rest of the response.

Code 02: Other incorrect responses. For example, the response does not refer to the characteristics of the graph, as the question clearly asks about how the GRAPH shows ...

- Girls mature early.
- Because females go through puberty before males do and they get their growth spurt earlier.
- Girls don't grow much after 12. [Gives a statement that girls' growth slows down after 12 years of age, and no reference to the graph is mentioned.]

Code 99: Missing.

---

**Question 2: GROWING UP**

*M150Q02- 00 11 21 22 99*

According to this graph, on average, during which period in their life are females taller than males of the same age?

.....  
.....

## **GROWING UP SCORING 2**

### ***Full credit***

Code 21: Gives the correct interval, from 11-13 years.

- Between age 11 and 13.
- From 11 years old to 13 years old, girls are taller than boys on average.
- 11-13.

Code 22: States that girls are taller than boys when they are 11 and 12 years old. (This answer is correct in daily-life language, because it means the interval from 11 to 13).

- Girls are taller than boys when they are 11 and 12 years old.
- 11 and 12 years old.

### ***Partial credit***

Code 11: Other subsets of (11, 12, 13), not included in the full credit section.

- 12 to 13.
- 12.
- 13.
- 11.
- 11.2 to 12 .8.

### ***No credit***

Code 00: Other responses.

- 1998.
- Girls are taller than boys when they're older than 13 years.
- Girls are taller than boys from 10 to 11.

Code 99: Missing.



## M154: Pizzas

---

A pizzeria serves two round pizzas of the same thickness in different sizes. The smaller one has a diameter of 30 cm and costs 30 zeds. The larger one has a diameter of 40 cm and costs 40 zeds.

---

### Question 1: PIZZAS

M154Q01- 0 1 2 8 9

Which pizza is better value for money? Show your reasoning.

#### PIZZAS SCORING 1

QUESTION INTENT: Applies understanding of area to solving a value for money comparison

- Code 2: Gives general reasoning that the surface area of pizza increases more rapidly than the price of pizza to conclude that the larger pizza is better value.
- The diameter of the pizzas is the same number as their price, but the amount of pizza you get is found using diameter<sup>2</sup>, so you will get more pizza per zeds from the larger one
- Code 1: Calculates the area and amount per zed for each pizza to conclude that the larger pizza is better value.
- Area of smaller pizza is  $0.25 \times \pi \times 30 \times 30 = 225\pi$ ; amount per zed is  $23.6 \text{ cm}^2$   
area of larger pizza is  $0.25 \times \pi \times 40 \times 40 = 400\pi$ ; amount per zed is  $31.4 \text{ cm}^2$   
so larger pizza is better value
- Code 8: They are the same value for money. (This incorrect answer is coded separately, because we would like to keep track of how many students have this misconception).
- Code 0: Other incorrect responses OR a correct answer without correct reasoning.
- Code 9: Missing.

## M158: Shapes

---

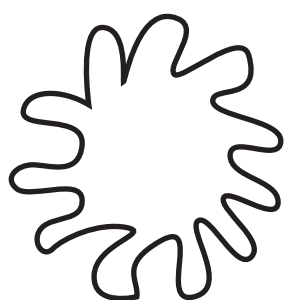

A

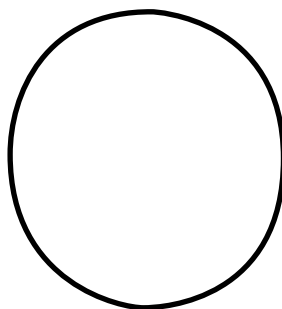

B

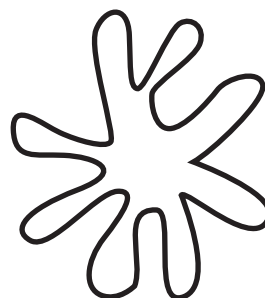

C

---

### Question 1: SHAPES

M158Q01- 0 1 8 9

Which of the figures has the largest area? Explain your reasoning.

#### SHAPES SCORING 1

QUESTION INTENT: Comparison of areas of irregular shapes

Code 1: Shape B, supported with plausible reasoning.

- It's the largest area because the others will fit inside it.

Code 8: Shape B, without plausible support.

Code 0: Other responses.

Code 9: Missing.

#### *Example responses*

Code 1:

- B. It doesn't have indents in it which decreases the area. A and C have gaps.
- B, because it's a full circle, and the others are like circles with bits taken out.
- B, because it has no open areas:



Code 8:

- B. because it has the largest surface area
- The circle. It's pretty obvious.
- B, because it is bigger.

Code 0:

- They are all the same.

---

## Question 2: SHAPES

M158Q02- 0 1 8 9

Describe a method for estimating the area of figure C.

### SHAPES SCORING 2

QUESTION INTENT: To assess students' strategies for measuring areas of irregular shapes.

Code 1: Reasonable method:

- Draw a grid of squares over the shape and count the squares that are more than half filled by the shape.
- Cut the arms off the shape and rearrange the pieces so that they fill a square then measure the side of the square.
- Build a 3D model based on the shape and fill it with water. Measure the amount of water used and the depth of the water in the model. Derive the area from the information.

Code 8: Partial answers:

- The student suggests to find the area of the circle and subtract the area of the cut out pieces. However, the student does not mention about how to find out the area of the cut out pieces.
- Add up the area of each individual arm of the shape

Code 0: Other responses.

Code 9: Missing.

### NOTE:

The key point for this question is whether the student offers a METHOD for determining the area. The coding schemes (1, 8, 0) is a hierarchy of the extent to which the student describes a METHOD.

### Example responses

Code 1:

- You could fill the shape with lots of circles, squares and other basic shapes so there is not a gap. Work out the area of all of the shapes and add together.
- Redraw the shape onto graph paper and count all of the squares it takes up.
- Drawing and counting equal size boxes. Smaller boxes = better accuracy *(Here the student's description is brief, but we will be lenient about student's writing skills and regard the method offered by the student as correct)*
- Make it into a 3D model and filling it with exactly 1cm of water and then measure the volume of water required to fill it up.

Code 8:

- Find the area of B then find the areas of the cut out pieces and subtract them from the main area.
- Minus the shape from the circle
- Add up the area of each individual piece e.g.,
- Use a shape like that and pour a liquid into it.
- Use graph
- Half of the area of shape B
- Figure out how many  $\text{mm}^2$  are in one little leg things and times it by 8.

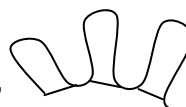

Code 0:

- Use a string and measure the perimeter of the shape. Stretch the string out to a circle and measure the area of the circle using  $\pi r^2$ .  
(Here the method described by the student is wrong)

---

### Question 3: SHAPES

M158Q03- 0 1 8 9

Describe a method for estimating the perimeter of figure C.

#### SHAPES SCORING 3

QUESTION INTENT: To assess students' strategies for measuring perimeters of irregular shapes

Code 1: Reasonable method:

- Lay a piece of string over the outline of the shape then measure the length of string used.
- Cut the shape up into short, nearly straight pieces and join them together in a line, then measure the length of the line.
- Measure the length of some of the arms to find an average arm length then multiply by 8 (number of arms) X 2.

Code 0: Other responses.

Code 9: Missing.

#### Example responses

Code 1:

- Wool or string!!!  
(Here although the answer is brief, the student did offer a METHOD for measuring the perimeter)
- Cut the side of the shape into sections. Measure each then add them together.  
(Here the student did not explicitly say that each section needs to be approximately straight, but we will give the benefit of the doubt, that is, by offering the METHOD of cutting the shape into pieces, each piece is assumed to be easily measurable)

Code 0:

- Measure around the outside.  
(Here the student did not suggest any METHOD of measuring. Simply saying "measure it" is not offering any method of how to go about measuring it)
- Stretch out the shape to make it a circle.  
(Here although a method is offered by the student, the method is wrong)

## M159: Speed of Racing Car

---

This graph shows how the speed of a racing car varies along a flat 3 kilometre track during its second lap.

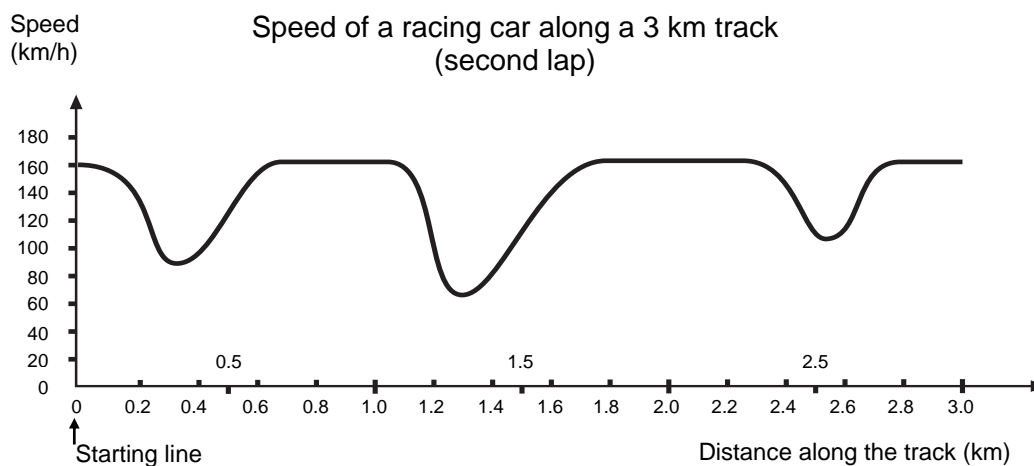

---

### Question 1: SPEED OF RACING CAR

M159Q01

What is the approximate distance from the starting line to the beginning of the longest straight section of the track?

- A 0.5 km
- B 1.5 km
- C 2.3 km
- D 2.6 km

### SPEED OF RACING CAR SCORING 1

#### **Full credit**

Code 1: B. 1.5 km

#### **No credit**

Code 0: Other responses.

Code 9: Missing.

---

**Question 2: SPEED OF RACING CAR**

M159Q02

Where was the lowest speed recorded during the second lap?

- A. at the starting line.
- B. at about 0.8 km.
- C. at about 1.3 km.
- D. halfway around the track.

**SPEED OF RACING CAR SCORING 2****Full credit**

Code 1: C. at about 1.3 km.

**No credit**

Code 0: Other responses.

Code 9: Missing.

---

**Question 3: SPEED OF RACING CAR**

M159Q03

What can you say about the speed of the car between the 2.6 km and 2.8 km marks?

- A. The speed of the car remains constant.
- B. The speed of the car is increasing.
- C. The speed of the car is decreasing.
- D. The speed of the car cannot be determined from the graph.

**SPEED OF RACING CAR SCORING 3****Full credit**

Code 1: B. The speed of the car is increasing.

**No credit**

Code 0: Other responses.

Code 9: Missing.

---

**Question 4: SPEED OF RACING CAR**

M159Q04

Here are pictures of five tracks:

Along which one of these tracks was the car driven to produce the speed graph shown earlier?

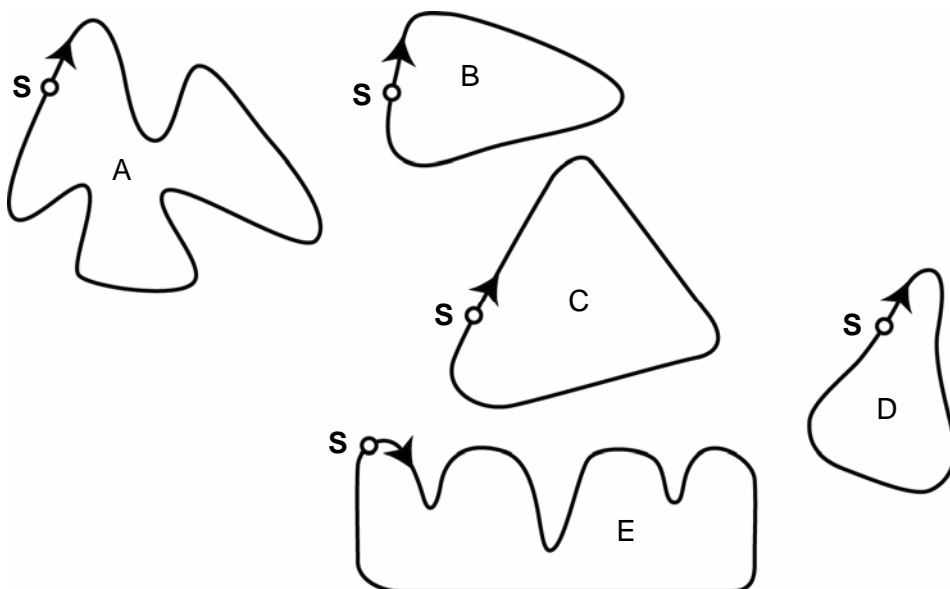

**S: Starting point**

**SPEED OF RACING CAR SCORING 4**

**Full credit**

Code 1: B

**No credit**

Code 0: Other responses.

Code 9: Missing.

# M161: Triangles

## Question 1: TRIANGLES

M161Q01

Circle the one figure below that fits the following description.

Triangle PQR is a right triangle with right angle at R. The line RQ is less than the line PR. M is the midpoint of the line PQ and N is the midpoint of the line QR. S is a point inside the triangle. The line MN is greater than the line MS.

A

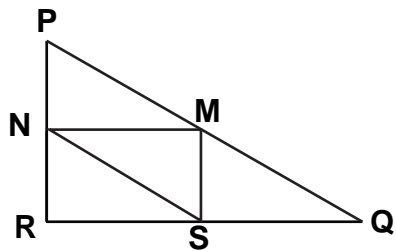

B

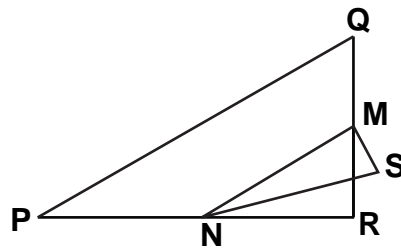

C

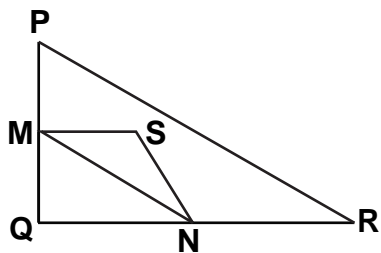

D

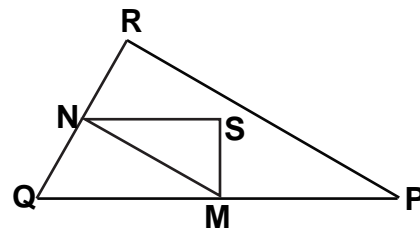

E

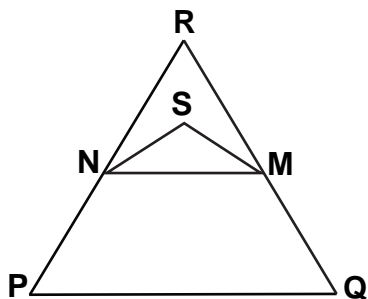



## TRIANGLES SCORING 1

### ***Full credit***

Code 1: Answer D.

### ***No credit***

Code 0: Other responses.

Code 9: Missing.

## M179: Robberies

---

### Question 1: ROBBERIES

M179Q01- 01 02 03 04 11 12 21 22 23 99

A TV reporter showed this graph and said:

“The graph shows that there is a huge increase in the number of robberies from 1998 to 1999.”

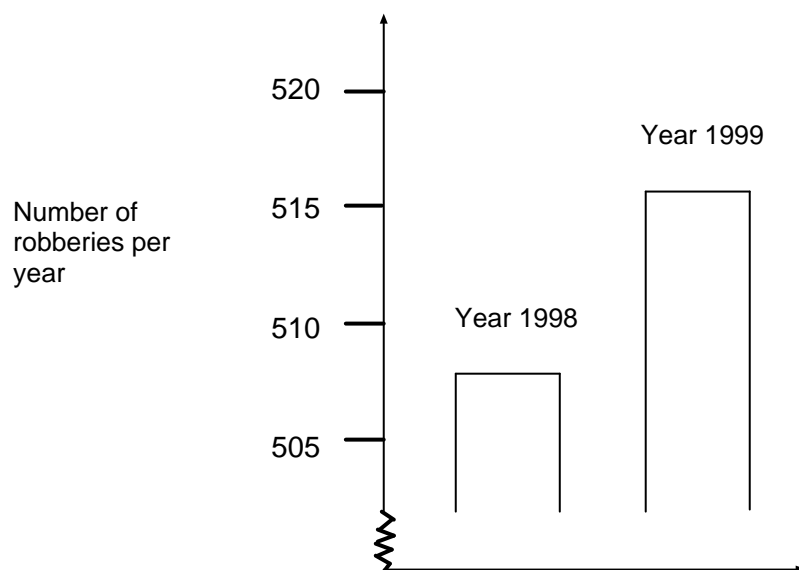

Do you consider the reporter's statement to be a reasonable interpretation of the graph? Give an explanation to support your answer.

### ROBBERIES SCORING 1

#### NOTE:

The use of NO in these codes includes all statements indicating that the interpretation of the graph is NOT reasonable. YES includes all statements indicating that the interpretation is reasonable. Please assess whether the student's response indicates that the interpretation of the graph is reasonable or not reasonable, and do not simply take the words "YES" or "NO" as criteria for codes.]

#### *Full credit*

Code 21: No, not reasonable. Focuses on the fact that only a **small part** of the graph is shown.

- Not reasonable. The entire graph should be displayed.
- I don't think it is a reasonable interpretation of the graph because if they were to show the whole graph you would see that there is only a slight increase in robberies.
- No, because he has used the top bit of the graph and if you looked at the whole graph from 0 – 520, it wouldn't have risen so much.

- No, because the graph makes it look like there's been a big increase but you look at the numbers and there's not much of an increase.

Code 22: No, not reasonable. Contains correct arguments in terms of ratio or percentage increase.

- No, not reasonable. 10 is not a huge increase compared to a total of 500.
- No, not reasonable. According to the percentage, the increase is only about 2%.
- No. 8 more robberies is 1.5% increase. Not much in my opinion!
- No, only 8 or 9 more for this year. Compared to 507, it is not a large number.

Code 23: Trend data is required before a judgement can be made.

- We can't tell whether the increase is huge or not. If in 1997, the number of robberies is the same as in 1998, then we could say there is a huge increase in 1999.
- There is no way of knowing what "huge" is because you need at least two changes to think one huge and one small.

***Partial credit***

Code 11: No, not reasonable, but explanation lacks detail.

- Focuses ONLY on an increase given by the exact number of robberies, but does not compare with the total.
- Not reasonable. It increased by about 10 robberies. The word "huge" does not explain the reality of the increased number of robberies. The increase was only about 10 and I wouldn't call that "huge".
- From 508 to 515 is not a large increase.
- No, because 8 or 9 is not a large amount.
- Sort of. From 507 to 515 is an increase, but not huge.

**NOTE:**

As the scale on the graph is not that clear, accept between 5 and 15 for the increase of the exact number of robberies.

Code 12: No, not reasonable, with correct method but with minor computational errors.

- Correct method and conclusion but the percentage calculated is 0.03%.

***No credit***

Code 01: No, with no, insufficient or incorrect explanation.

- No, I don't agree.
- The reporter should not have used the word "huge".
- No, it's not reasonable. Reporters always like to exaggerate.

Code 02: Yes, focuses on the appearance of the graph and mentions that the number of robberies doubled.

- Yes, the graph doubles its height.
- Yes, the number of robberies has almost doubled.

Code 03: Yes, with no explanation, or explanations other than Code 02.

Code 04: Other responses.

Code 99: Missing.

## M215: Braking

The approximate distance to stop a moving vehicle is the sum of:

- the distance covered during the time the driver takes to begin to apply the brakes (reaction-time distance)
- the distance travelled while the brakes are applied (braking distance)

The 'snail' diagram below gives the theoretical stopping distance for a vehicle in good braking conditions (a particularly alert driver, brakes and tyres in perfect condition, a dry road with a good surface) and how much the stopping distance depends on speed.

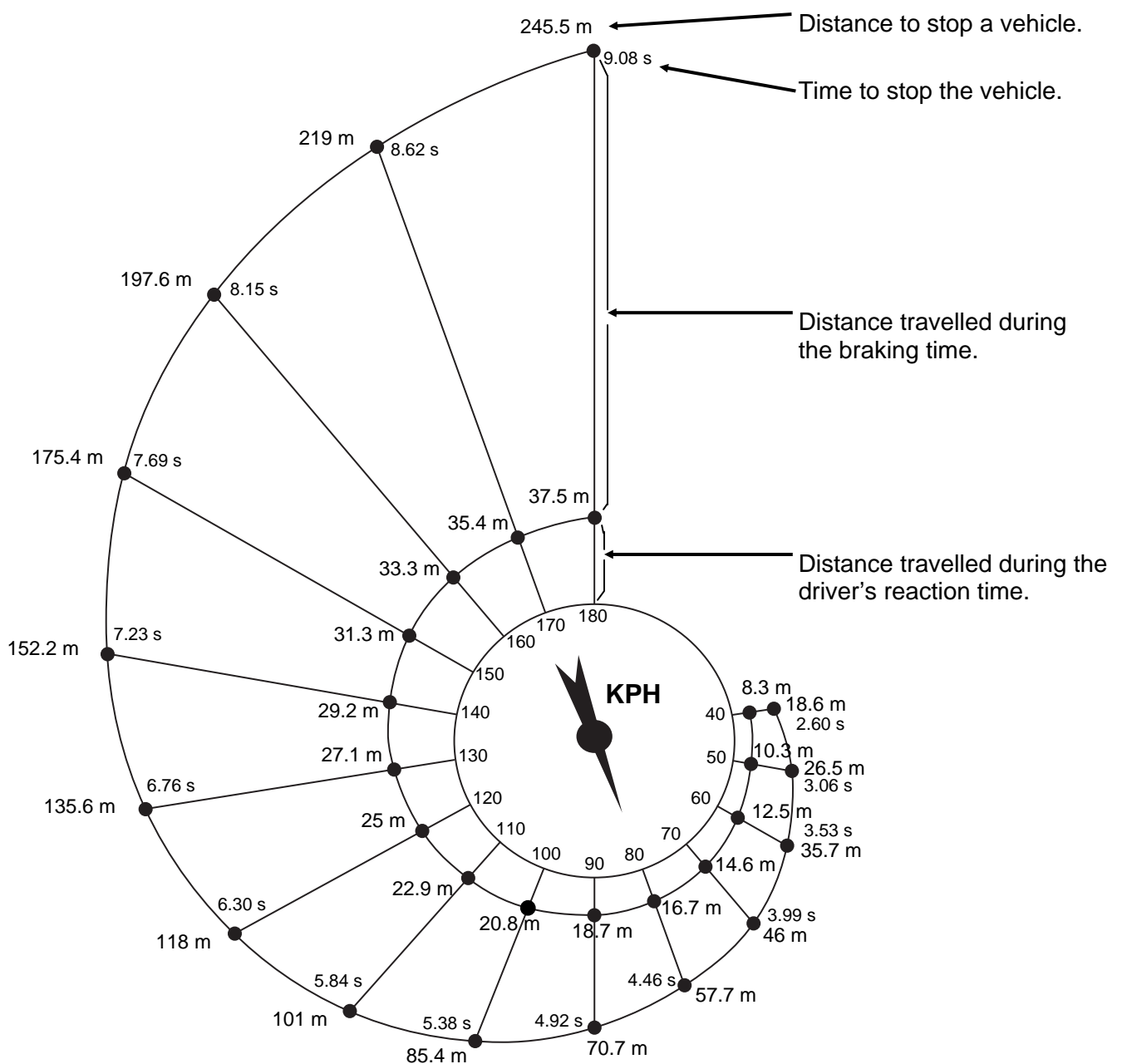

---

**QUESTION 1: BRAKING***M215Q01*

If a vehicle is travelling at 110 kph, what distance does the vehicle travel during the driver's reaction time?

**BRAKING 1 SCORING GUIDE**

QUESTION INTENT: Ability to read a information from a diagram.

Code 1: 22.9 metres (units not required)

Code 0: Other responses.

Code 9: Missing.

---

**Question 2: BRAKING***M215Q01*

If a vehicle is travelling at 110 kph, what is the total distance travelled before the vehicle stops?

**BRAKING SCORING 2**

QUESTION INTENT: Ability to read a information from a diagram.

Code 1: 101 metres (units not required)

Code 0: Other responses.

Code 9: Missing.

---

**Question 3: BRAKING***M215Q03*

If a vehicle is travelling at 110 kph, how long does it take to stop the vehicle completely?

**BRAKING 3 SCORING GUIDE**

QUESTION INTENT: Ability to read a information from a diagram.

Code 1: 5.84 seconds (units not required)

Code 0: Other responses.

Code 9: Missing.

---

**Question 4: BRAKING***M215Q04*

If a vehicle is travelling at 110 kph, what is the distance travelled while the brakes are being applied?

**BRAKING 4 SCORING GUIDE**

QUESTION INTENT: Ability to derive a information from a diagram.

Code 1: 78.1 metres (units not required)

Code 0: Other responses.

Code 9: Missing.

---

**Question 5: BRAKING***M215Q05*

A second driver, travelling in good conditions, stops her vehicle in a total distance of 70.7 metres. At what speed was the vehicle travelling before the brakes were applied?

**BRAKING 5 SCORING GUIDE**

QUESTION INTENT: Ability to read information from a diagram.

Code 1: 90 kph (units not necessary)

Code 0: Other responses.

Code 9 : Missing.

## M266: Carpenter

### Question 1: CARPENTER

M266Q01

A carpenter has 32 metres of timber and wants to make a border around a garden bed. He is considering the following designs for the garden bed.

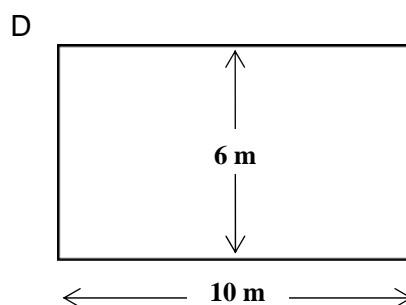
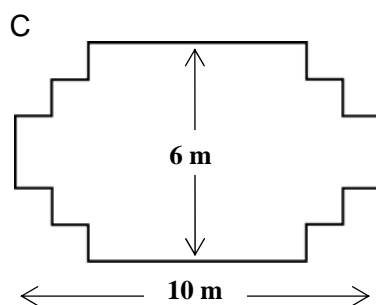
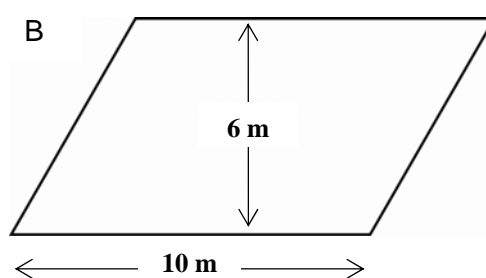
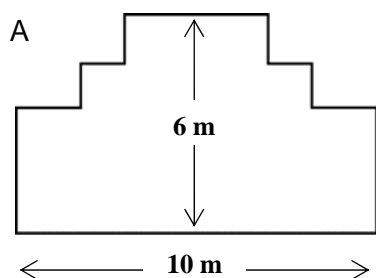

Circle either "Yes" or "No" for each design to indicate whether the garden bed can be made with 32 metres of timber.

Garden bed design	Using this design, can the garden bed be made with 32 metres of timber?
Design A	Yes / No
Design B	Yes / No
Design C	Yes / No
Design D	Yes / No

## **CARPENTER SCORING 1**

### ***Full credit***

Code 2: Exactly four correct

Design A Yes

Design B No

Design C Yes

Design D Yes

### ***Partial credit***

Code 1: Exactly three correct.

### ***No credit***

Code 0: Two or fewer correct.

Code 9: Missing.



## M267: Patio

---

### Question 1: PATIO

M267Q01- 0 1 2 8 9

Nick wants to pave the rectangular patio of his new house. The patio has length 5.25 metres and width 3.00 metres. He needs 81 bricks per square metre.

Calculate how many bricks Nick needs for the whole patio.

### PATIO SCORING 1

#### **Full credit**

Code 2: 1275, 1276 or 1275.75 (unit not required).

#### **Partial credit**

Code 1: 15.75 (units not required)

OR

1215 bricks for 5m X 3m

*(This score is used for students who are able to calculate the number of bricks for an integer number of square metres, but not for fractions of square metres. See example response.)*

OR

Error in calculating the area, but multiplied by 81 correctly

OR

Rounded off the area and then multiplied by 81 correctly

#### **No credit**

Code 0: Other responses.

Code 9: Missing.

**Example responses**

Code 2:

- $5.25 \times 3 = 15.75 \times 81 = 1276$

Code 1:

- $5.25 \times 3 = 15.75$
- $15.75 \times 81 = 9000$
- $81 \times 15 = 1215$ ;  $1215 + 21 = 1236$
- $5.25 \times 3.0 = 15.75 \text{ m}^2$ ; so  $15.75 \times 1275.75 = 1376$  bricks.  
*(Here the student got the first part right, but the second part wrong. Give credit for the first part and ignore the second part. So score as 1)*

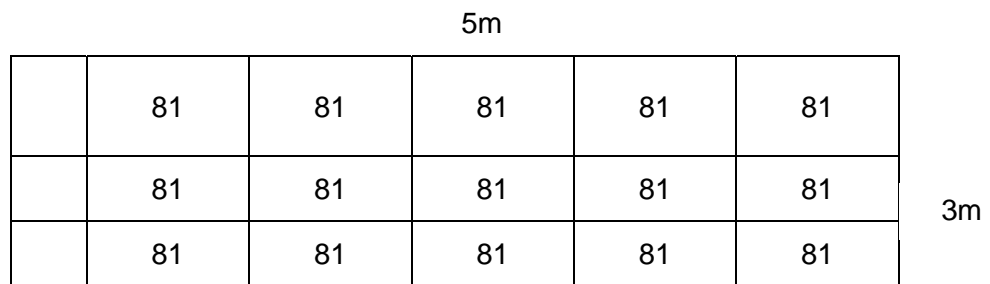

## M307: Drug Concentrations

---

### Question 1: DRUG CONCENTRATIONS

M307Q01 - 0 1 2 9

A woman in hospital receives an injection of penicillin. Her body gradually breaks the penicillin down so that one hour after the injection only 60% of the penicillin will remain active.

This pattern continues: at the end of each hour only 60% of the penicillin that was present at the end of the previous hour remains active.

Suppose the woman is given a dose of 300 milligrams of penicillin at 8 o'clock in the morning.

Complete this table showing the amount of penicillin that will remain active in the woman's blood at intervals of one hour from 0800 until 1100 hours.

Time	0800	0900	1000	1100
Penicillin (mg)	300			

### DRUG CONCENTRATIONS SCORING 1

#### *Full credit*

Code 2: All three table entries correct.

Time	0800	0900	1000	1100
Penicillin (mg)	300	180	108	64.8 or 65

#### *Partial credit*

Code 1: One or two table entries correct.

#### *No credit*

Code 0: Other responses.

Code 9: Missing.

---

**Question 2: DRUG CONCENTRATIONS**

M307Q02

Peter has to take 80 mg of a drug to control his blood pressure. The following graph shows the initial amount of the drug, and the amount that remains active in Peter's blood after one, two, three and four days.

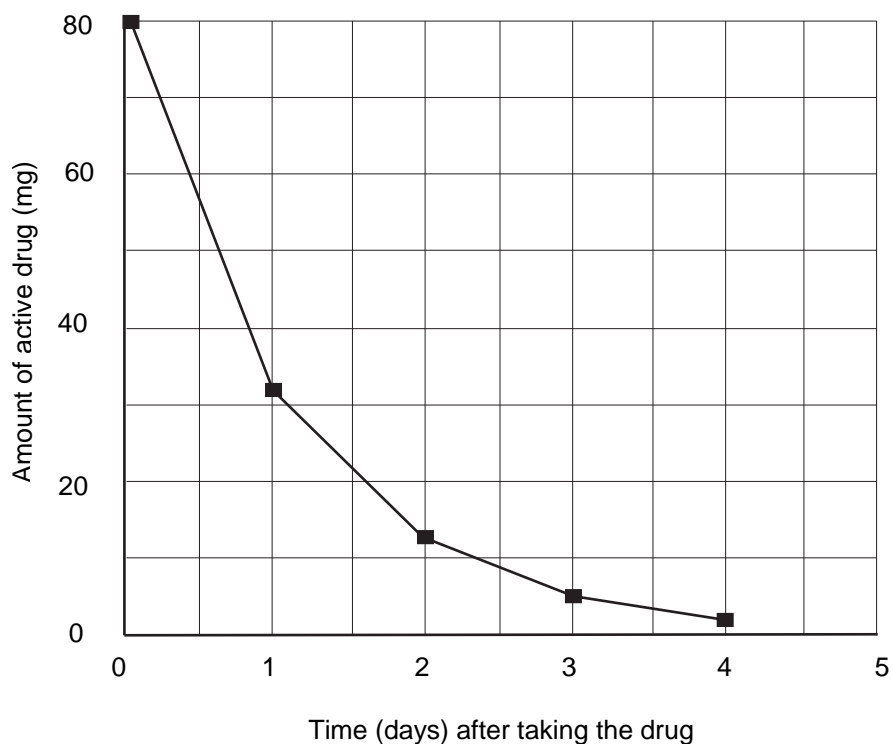

How much of the drug remains active at the end of the first day?

- A 6 mg.
- B 12 mg.
- C 26 mg.
- D 32 mg.

**DRUG CONCENTRATIONS SCORING 2****Full credit**

Code 1: D. 32mg.

**No credit**

Code 0: Other responses.

Code 9: Missing.

---

**Question 3: DRUG CONCENTRATIONS***M307Q03*

From the graph for the previous question it can be seen that each day, about the same proportion of the previous day's drug remains active in Peter's blood.

At the end of each day which of the following is the approximate percentage of the previous day's drug that remains active?

- A 20%.
- B 30%.
- C 40%.
- D 80%.

**DRUG CONCENTRATIONS SCORING 3*****Full credit***

Code 1: C. 40%.

***No credit***

Code 0: Other responses.

Code 9: Missing.

## M309: Building Blocks

---

Susan likes to build blocks from small cubes like the one shown in the following diagram:

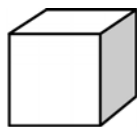

Small cube

Susan has lots of small cubes like this one. She uses glue to join cubes together to make other blocks.

First, Susan glues eight of the cubes together to make the block shown in Diagram A:

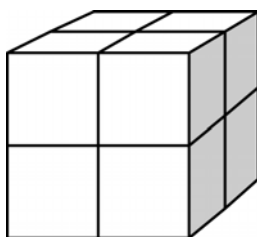

Diagram A

Then Susan makes the solid blocks shown in Diagram B and Diagram C below:

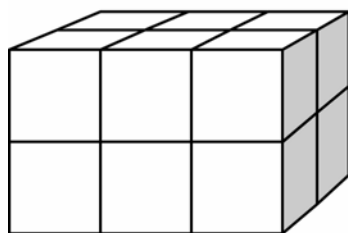

Diagram B

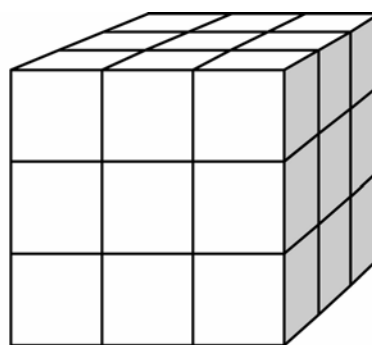

Diagram C

---

**Question 1: BUILDING BLOCKS***M309Q01*

How many small cubes will Susan need to make the block shown in Diagram B?

Answer: .....cubes.

**BUILDING BLOCKS SCORING 1*****Full credit***

Code 1: 12 cubes.

***No credit***

Code 0: Other responses.

Code 9: Missing.

---

**Question 2: BUILDING BLOCKS***M309Q02*

How many small cubes will Susan need to make the solid block shown in Diagram C?

Answer: .....cubes.

**BUILDING BLOCKS SCORING 2*****Full credit***

Code 1: 27 cubes.

***No credit***

Code 0: Other responses.

Code 9: Missing.

---

**Question 3: BUILDING BLOCKS***M309Q03*

Susan realises that she used more small cubes than she really needed to make a block like the one shown in Diagram C. She realises that she could have glued small cubes together to look like Diagram C, but the block could have been hollow on the inside.

What is the minimum number of cubes she needs to make a block that looks like the one shown in Diagram C, but is hollow?

Answer: .....cubes.

**BUILDING BLOCKS SCORING 3*****Full credit***

Code 1: 26 cubes.

***No credit***

Code 0: Other responses.

Code 9: Missing.

---

**Question 4: BUILDING BLOCKS***M309Q04*

Now Susan wants to make a block that looks like a solid block that is 6 small cubes long, 5 small cubes wide and 4 small cubes high. She wants to use the smallest number of cubes possible, by leaving the largest possible hollow space inside the block.

What is the minimum number of cubes Susan will need to make this block?

Answer: .....cubes.

**BUILDING BLOCKS SCORING 4*****Full credit***

Code 1: 96 cubes.

***No credit***

Code 0: Other responses.

Code 9: Missing.



## M402: Internet Relay Chat

---

Mark (from Sydney, Australia) and Hans (from Berlin, Germany) often communicate with each other using “chat” on the Internet. They have to log on to the Internet at the same time to be able to chat.

To find a suitable time to chat, Mark looked up a chart of world times and found the following:

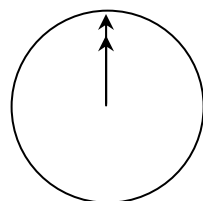

Greenwich 12 Midnight

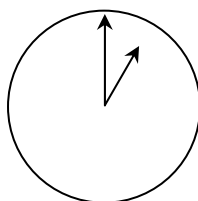

Berlin 1:00 AM

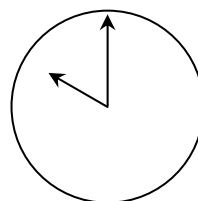

Sydney 10:00 AM

---

### Question 1: INTERNET RELAY CHAT

M402Q01 - 0 1 9

At 7:00 PM in Sydney, what time is it in Berlin?

Answer: .....

### INTERNET RELAY CHAT SCORING 1

#### **Full credit**

Code 1: 10 AM or 10:00.

#### **No credit**

Code 0: Other responses.

Code 9: Missing.

---

**Question 2: INTERNET RELAY CHAT**

M402Q02 - 0 1 9

Mark and Hans are not able to chat between 9:00 AM and 4:30 PM their local time, as they have to go to school. Also, from 11:00 PM till 7:00 AM their local time they won't be able to chat because they will be sleeping.

When would be a good time for Mark and Hans to chat? Write the local times in the table.

Place	Time
Sydney	
Berlin	

**INTERNET RELAY CHAT SCORING 2****Full credit**

Code 1: Any time or interval of time satisfying the 9 hours time difference and taken from one of these intervals:

Sydney: 4:30 PM – 6:00 PM; Berlin: 7:30 AM – 9:00 AM

OR

Sydney: 7:00 AM – 8:00 AM; Berlin: 10:00 PM – 11:00 PM

- Sydney 17:00, Berlin 8:00.

**NOTE:**

If an interval is given, the entire interval must satisfy the constraints. Also, if morning (AM) or evening (PM) is not specified, but the times could otherwise be regarded as correct, the response should be given the benefit of the doubt, and coded as correct.

**No credit**

Code 0: Other responses, including one time correct, but corresponding time incorrect.

- Sydney 8 am, Berlin 10 pm.

Code 9: Missing.

## M413: Exchange Rate

---

Mei-Ling from Singapore was preparing to go to South Africa for 3 months as an exchange student. She needed to change some Singapore dollars (SGD) into South African rand (ZAR).

---

### Question 1: EXCHANGE RATE

M413Q01 - 0 1 9

Mei-Ling found out that the exchange rate between Singapore dollars and South African rand was:

$$1 \text{ SGD} = 4.2 \text{ ZAR}$$

Mei-Ling changed 3000 Singapore dollars into South African rand at this exchange rate.

How much money in South African rand did Mei-Ling get?

Answer: .....

### EXCHANGE RATE SCORING 1

#### *Full credit*

Code 1: 12 600 ZAR (unit not required).

#### *No credit*

Code 0: Other responses.

Code 9: Missing.

---

### Question 2: EXCHANGE RATE

M413Q02 - 0 1 9

On returning to Singapore after 3 months, Mei-Ling had 3 900 ZAR left. She changed this back to Singapore dollars, noting that the exchange rate had changed to:

$$1 \text{ SGD} = 4.0 \text{ ZAR}$$

How much money in Singapore dollars did Mei-Ling get?

Answer: .....

## EXCHANGE RATE SCORING 2

### **Full credit**

Code 1: 975 SGD (unit not required).

### **No credit**

Code 0: Other responses.

Code 9: Missing.

---

## Question 3: EXCHANGE RATE

M413Q03 - 01 02 11 99

During these 3 months the exchange rate had changed from 4.2 to 4.0 ZAR per SGD.

Was it in Mei-Ling's favour that the exchange rate now was 4.0 ZAR instead of 4.2 ZAR, when she changed her South African rand back to Singapore dollars? Give an explanation to support your answer.

## EXCHANGE RATE SCORING 3

### **Full credit**

Code 11: 'Yes', with adequate explanation.

- Yes, by the lower exchange rate (for 1 SGD) Mei-Ling will get more Singapore dollars for her South African rand.
- Yes, 4.2 ZAR for one dollar would have resulted in 929 ZAR. [Note: student wrote ZAR instead of SGD, but clearly the correct calculation and comparison have been carried out and this error can be ignored]
- Yes, because she received 4.2 ZAR for 1 SGD, and now she has to pay only 4.0 ZAR to get 1 SGD.
- Yes, because it is 0.2 ZAR cheaper for every SGD.
- Yes, because when you divide by 4.2 the outcome is smaller than when you divide by 4.
- Yes, it was in her favour because if it didn't go down she would have got about \$50 less.

### **No credit**

Code 01: 'Yes', with no explanation or with inadequate explanation.

- Yes, a lower exchange rate is better.
- Yes it was in Mei-Ling's favour, because if the ZAR goes down, then she will have more money to exchange into SGD.
- Yes it was in Mei-Ling's favour.

Code 02: Other responses.

Code 99: Missing.

## M432: Reaction Time

---

In a Sprinting event, the 'reaction time' is the time interval between the starter's gun firing and the athlete leaving the starting block. The 'final time' includes both this reaction time, and the running time.



The following table gives the reaction time and the final time of 8 runners in a 100 metre sprint race.

Lane	Reaction time (sec)	Final time (sec)
1	0.147	10.09
2	0.136	9.99
3	0.197	9.87
4	0.180	Did not finish the race
5	0.210	10.17
6	0.216	10.04
7	0.174	10.08
8	0.193	10.13

---

**Question 1: REACTION TIME**

M432Q01 - 0 1 9

Identify the Gold, Silver and Bronze medallists from this race. Fill in the table below with the medallists' lane number, reaction time and final time.

<b>Medal</b>	<b>Lane</b>	<b>Reaction time (secs)</b>	<b>Final time (secs)</b>
GOLD			
SILVER			
BRONZE			

**REACTION TIME SCORING 1*****Full credit***

Code 1:

<b>Medal</b>	<b>Lane</b>	<b>Reaction time (secs)</b>	<b>Final time (secs)</b>
GOLD	3	0.197	9.87
SILVER	2	0.136	9.99
BRONZE	6	0.216	10.04

***No credit***

Code 0: Other responses.

Code 9: Missing.

---

**Question 2: REACTION TIME**

M432Q02 - 0 1 9

To date, no humans have been able to react to a starter's gun in less than 0.110 second.

If the recorded reaction time for a runner is less than 0.110 second, then a false start is considered to have occurred because the runner must have left before hearing the gun.

If the Bronze medallist had a faster reaction time, would he have had a chance to win the Silver medal? Give an explanation to support your answer.

**REACTION TIME SCORING 2*****Full credit***

Code 1: Yes, with adequate explanation.

- Yes. If he had a reaction time of 0.05 sec faster, he would have equalled second place.
- Yes, he would have a chance to win the Silver medal if his reaction time was less than or equal to 0.166 sec.
- Yes, with the fastest possible reaction time he would have done a 9.93 which is good enough for silver medal.

***No credit***

Code 0: Other responses, including yes without adequate explanation.

Code 9: Missing.

## M438: Exports

---

The graphics below show information about exports from Zedland, a country that uses zeds as its currency.

**Total annual exports from Zedland in millions of zeds, 1996-2000**

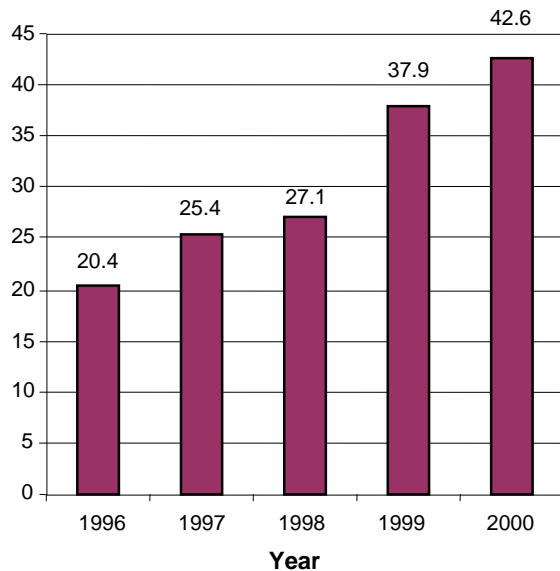

**Distribution of exports from Zedland in 2000**

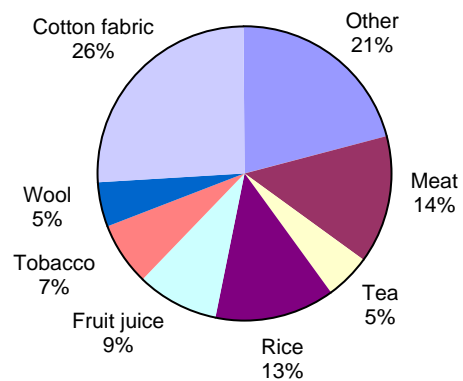

---

### Question 1: EXPORTS

M438Q01 - 0 1 9

What was the total value (in millions of zeds) of exports from Zedland in 1998?

Answer: .....

### EXPORTS SCORING 1

#### **Full credit**

Code 1: 27.1 million zeds or 27 100 000 zeds or 27.1 (unit not required).

#### **No credit**

Code 0: Other responses.

Code 9: Missing.



---

**Question 2: EXPORTS**

M438Q02

What was the value of fruit juice exported from Zedland in 2000?

- A 1.8 million zeds.
- B 2.3 million zeds.
- C 2.4 million zeds.
- D 3.4 million zeds.
- E 3.8 million zeds.

**EXPORTS SCORING 2*****Full credit***

Code 1: E. 3.8 million zeds.

***No credit***

Code 0: Other responses.

Code 9: Missing.

# M465: Water Tank

## Question 1: WATER TANK

M465Q01

A water tank has shape and dimensions as shown in the diagram.

At the beginning the tank is empty. Then it is filled with water at the rate of one litre per second.

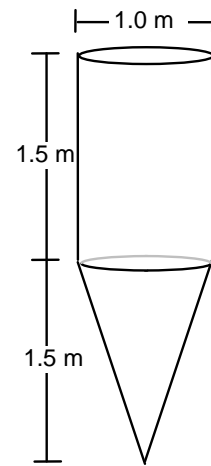

Water tank

Which of the following graphs shows how the height of the water surface changes over time?

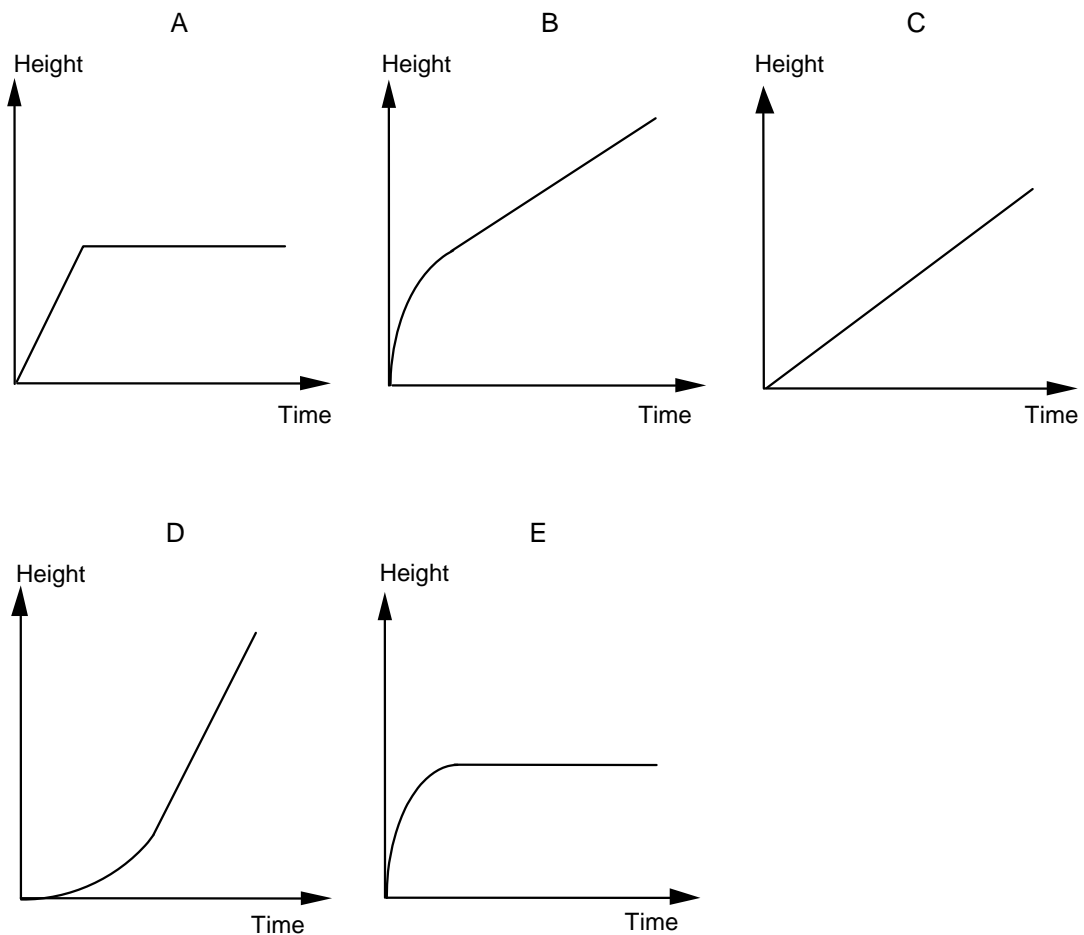

## WATER TANK SCORING 1

### ***Full credit***

Code 1: B.

### ***No credit***

Code 0: Other responses.

Code 9: Missing.

## M467: Coloured Candies

---

### Question 1: COLOURED CANDIES

M467Q01

Robert's mother lets him pick one candy from a bag. He can't see the candies. The number of candies of each colour in the bag is shown in the following graph.

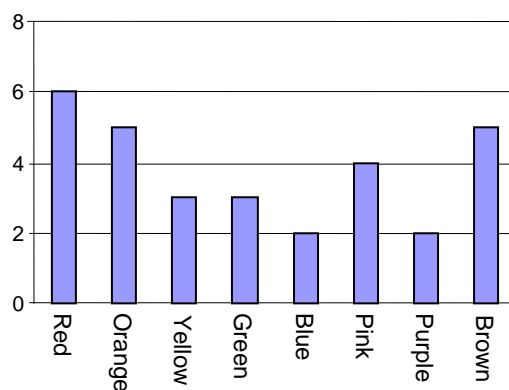

What is the probability that Robert will pick a red candy?

- A 10%
- B 20%
- C 25%
- D 50%

### COLOURED CANDIES SCORING 1

#### **Full credit**

Code 1: B. 20%.

#### **No credit**

Code 0: Other responses.

Code 9: Missing.

## M468: Science Tests

---

### Question 1: SCIENCE TESTS

M468Q01

In Mei Lin's school, her science teacher gives tests that are marked out of 100. Mei Lin has an average of 60 marks on her first four Science tests. On the fifth test she got 80 marks.

What is the average of Mei Lin's marks in Science after all five tests?

Average: .....

### SCIENCE TESTS SCORING 1

#### **Full credit**

Code 1: 64.

#### **No credit**

Code 0: Other responses.

Code 9: Missing.

## M471: Spring Fair

---

### Question 1: SPRING FAIR

M471Q01

A game in a booth at a spring fair involves using a spinner first. Then, **if** the spinner stops on an even number, the player is allowed to pick a marble from a bag. The spinner and the marbles in the bag are represented in the diagram below.

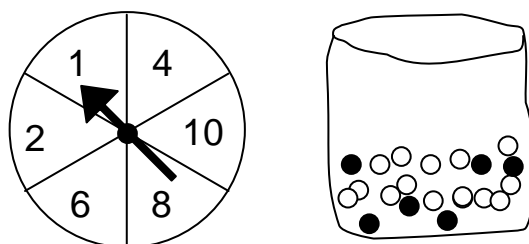

Prizes are given when a black marble is picked. Sue plays the game once.

How likely is it that Sue will win a prize?

- A Impossible.
- B Not very likely.
- C About 50% likely.
- D Very likely.
- E Certain.

### SPRING FAIR SCORING 1

#### **Full credit**

Code 1: B. Not very likely.

#### **No credit**

Code 0: Other responses.

Code 9: Missing.

## M472: Swing

### Question 1: SWING

M472Q01

Mohammed is sitting on a swing. He starts to swing. He is trying to go as high as possible.

Which diagram best represents the height of his feet above the ground as he swings?

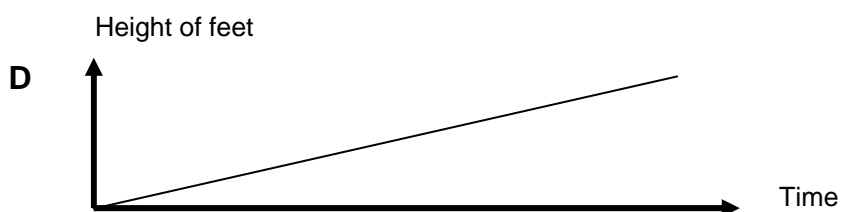
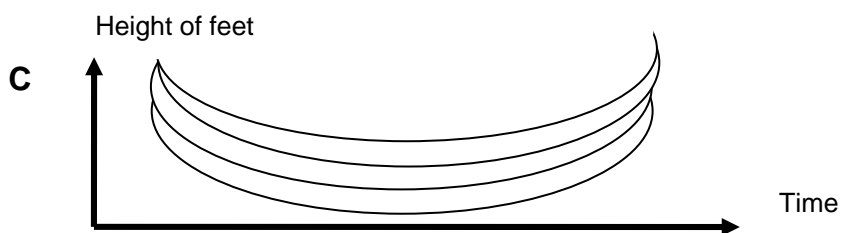
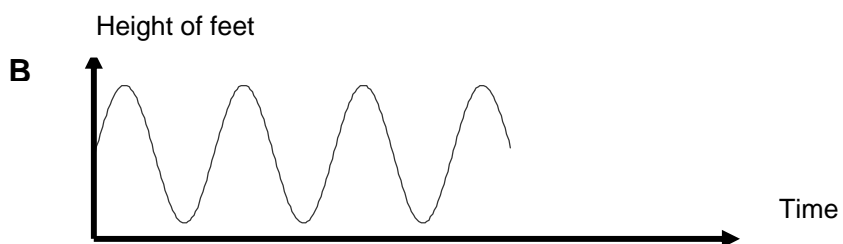
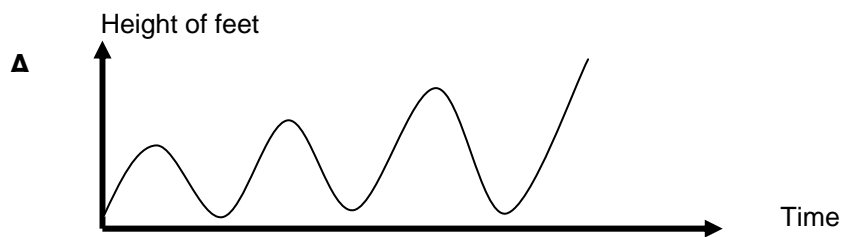

## **SWING SCORING 1**

### ***Full credit***

Code 1: A.

### ***No credit***

Code 0: Other responses.

Code 9: Missing.



## M479: Student Heights

---

### Question 1: STUDENT HEIGHTS

M479Q01

In a mathematics class one day, the heights of all students were measured. The average height of boys was 160 cm, and the average height of girls was 150 cm. Alena was the tallest – her height was 180 cm. Zdenek was the shortest – his height was 130 cm.

Two students were absent from class that day, but they were in class the next day. Their heights were measured, and the averages were recalculated. Amazingly, the average height of the girls and the average height of the boys did not change.

Which of the following conclusions can be drawn from this information?

Circle 'Yes' or 'No' for each conclusion.

Conclusion	Can this conclusion be drawn?
Both students are girls.	Yes / No
One of the students is a boy and the other is a girl.	Yes / No
Both students have the same height.	Yes / No
The average height of all students did not change.	Yes / No
Zdenek is still the shortest.	Yes / No

### STUDENT HEIGHTS SCORING 1

#### **Full credit**

Code 1: 'No' for all conclusions.

#### **No credit**

Code 0: Other responses.

Code 9: Missing.

## M480: Payments by Area

---

People living in an apartment building decide to buy the building. They will put their money together in such a way that each will pay an amount that is proportional to the size of their apartment.

For example, a man living in an apartment that occupies one fifth of the floor area of all apartments will pay one fifth of the total price of the building.

---

### Question 1: PAYMENTS BY AREA

M480Q01

Circle Correct or Incorrect for each of the following statements.

Statement	Correct / Incorrect
A person living in the largest apartment will pay more money for each square metre of his apartment than the person living in the smallest apartment.	Correct / Incorrect
If we know the areas of two apartments and the price of one of them we can calculate the price of the second.	Correct / Incorrect
If we know the price of the building and how much each owner will pay, then the total area of all apartments can be calculated.	Correct / Incorrect
If the total price of the building were reduced by 10%, each of the owners would pay 10% less.	Correct / Incorrect

### PAYMENTS BY AREA SCORING 1

#### **Full credit**

Code 1: Incorrect, Correct, Incorrect, Correct, in that order.

#### **No credit**

Code 0: Other responses.

Code 9: Missing.

---

**Question 2: PAYMENTS BY AREA**

M480Q02 - 0 1 2 9

There are three apartments in the building. The largest, apartment 1, has a total area of 95m<sup>2</sup>. Apartments 2 and 3 have areas of 85m<sup>2</sup> and 70m<sup>2</sup> respectively. The selling price for the building is 300 000 zeds.

How much should the owner of apartment 2 pay? Show your work.

**PAYMENTS BY AREA SCORING 2****Full credit**

Code 2: 102,000 zeds, with or without the calculation shown, and unit not required.

- Apartment 2: 102 000 zeds
- $Apt - 2 : \frac{85}{250} \times 300000 = 102000 \text{ zeds}$
- $\frac{300000}{250} = 1200$  zeds for each square metre, so Apartment 2 is 102 000.

**Partial credit**

Code 1: Correct method, but minor computational error/s.

- $Apt - 2 : \frac{85}{250} \times 300000 = 10200 \text{ zeds}$

**No credit**

Code 0: Other responses.

Code 9: Missing.

## M484: Bookshelves

---

### Question 1: BOOKSHELVES

M484Q01

To complete one set of bookshelves a carpenter needs the following components:

- 4 long wooden panels,
- 6 short wooden panels,
- 12 small clips,
- 2 large clips and
- 14 screws.

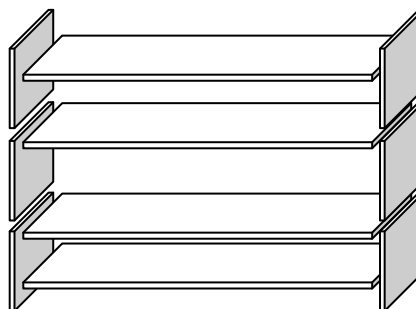

The carpenter has in stock 26 long wooden panels, 33 short wooden panels, 200 small clips, 20 large clips and 510 screws.

How many sets of bookshelves can the carpenter make?

Answer: .....

### BOOKSHELVES SCORING 1

#### ***Full credit***

Code 1: 5.

#### ***No credit***

Code 0: Other responses.

Code 9: Missing.

## M505: Litter

---

### Question 1: LITTER

M505Q01 - 0 1 9

For a homework assignment on the environment, students collected information on the decomposition time of several types of litter that people throw away:

Type of Litter	Decomposition time
Banana peel	1–3 years
Orange peel	1–3 years
Cardboard boxes	0.5 year
Chewing gum	20–25 years
Newspapers	A few days
Polystyrene cups	Over 100 years

A student thinks of displaying the results in a bar graph.

Give **one** reason why a bar graph is unsuitable for displaying these data.

### LITTER SCORING 1

#### *Full credit*

Code 1: Reason focuses on big variance in data.

- The difference in the lengths of the bars of the bar graph would be too big.
- If you make a bar with length 10 centimetres for polystyrene, the one for cardboard boxes would be 0.05 centimetres.

OR

Reason focuses on the variability of the data for some categories.

- The length of the bar for “polystyrene cups” is undetermined.
- You cannot make one bar for 1–3 years or one bar for 20–25 years.

#### *No credit*

Code 0: Other responses.

- Because it will not work.
- A pictogram is better.
- You cannot verify the info.
- Because the numbers in the table are only approximations.

Code 9: Missing.

## M509: Earthquake

---

### Question 1: EARTHQUAKE

M509Q01

A documentary was broadcast about earthquakes and how often earthquakes occur. It included a discussion about the predictability of earthquakes.

A geologist stated: "In the next twenty years, the chance that an earthquake will occur in Zed City is two out of three".

Which of the following best reflects the meaning of *the geologist's statement*?

- A  $\frac{2}{3} \times 20 = 13.3$ , so between 13 and 14 years from now there will be an earthquake in Zed City.
- B  $\frac{2}{3}$  is more than  $\frac{1}{2}$ , so you can be sure there will be an earthquake in Zed City at some time during the next 20 years.
- C The likelihood that there will be an earthquake in Zed City at some time during the next 20 years is higher than the likelihood of no earthquake.
- D You cannot tell what will happen, because nobody can be sure when an earthquake will occur.

### EARTHQUAKE SCORING 1

#### **Full credit**

Code 1: C. The likelihood that there will be an earthquake in Zed City at some time during the next 20 years is higher than the likelihood of no earthquake.

#### **No credit**

Code 0: Other responses.

Code 9: Missing.

## M510: Choices

---

### Question 1: CHOICES

M510Q01

In a pizza restaurant, you can get a basic pizza with two toppings: cheese and tomato. You can also make up your own pizza with **extra** toppings. You can choose from four different extra toppings: olives, ham, mushrooms and salami.

Ross wants to order a pizza with two different **extra** toppings.

How many different combinations can Ross choose from?

Answer: .....combinations.

### CHOICES SCORING 1

#### **Full credit**

Code 1: 6.

#### **No credit**

Code 0: Other responses.

Code 9: Missing.

## M513: Test Scores

### Question 1: TEST SCORES

M513Q01 - 0 1 9

The diagram below shows the results on a Science test for two groups, labelled as Group A and Group B.

The mean score for Group A is 62.0 and the mean for Group B is 64.5. Students pass this test when their score is 50 or above.

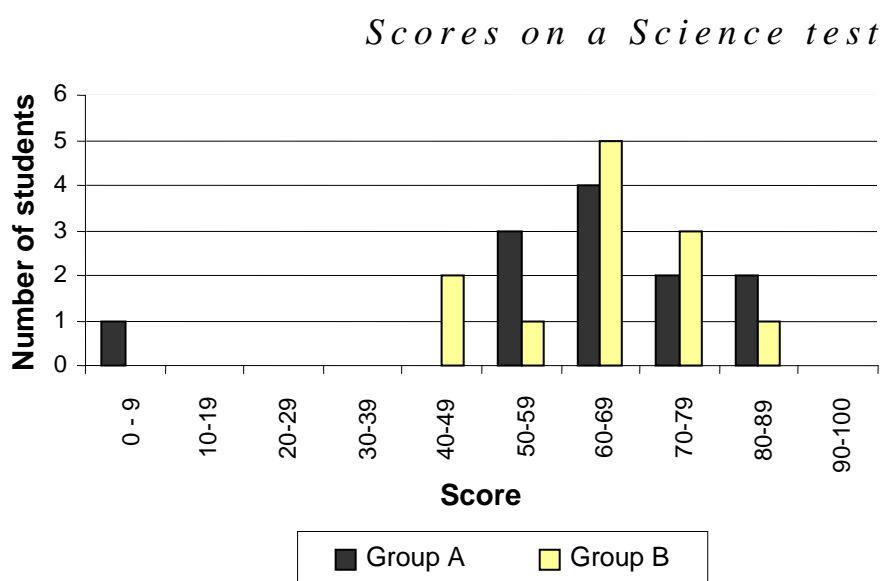

Looking at the diagram, the teacher claims that Group B did better than Group A in this test.

The students in Group A don't agree with their teacher. They try to convince the teacher that Group B may not necessarily have done better.

Give one mathematical argument, using the graph, that the students in Group A could use.

### TEST SCORES SCORING 1

#### *Full credit*

Code 1: One valid argument is given. Valid arguments could relate to the number of students passing, the disproportionate influence of the outlier, or the number of students with scores in the highest level.

- More students in Group A than in Group B passed the test.
- If you ignore the weakest Group A student, the students in Group A do better than those in Group B.
- More Group A students than Group B students scored 80 or over.



**No credit**

Code 0: Other responses, including responses with no mathematical reasons, or wrong mathematical reasons, or responses that simply describe differences but are not valid arguments that Group B may not have done better.

- Group A students are normally better than Group B students in science. This test result is just a coincidence.
- Because the difference between the highest and lowest scores is smaller for Group B than for Group A.
- Group A has better score results in the 80-89 range and the 50-59 range.
- Group A has a larger inter-quartile range than Group B.

Code 9: Missing.

## M515: Shoes for Kids

---

The following table shows the recommended Zedland shoe sizes corresponding to various foot lengths.



Conversion table for kids shoe sizes in Zedland

From (in mm)	To (in mm)	Shoe size
107	115	18
116	122	19
123	128	20
129	134	21
135	139	22
140	146	23
147	152	24
153	159	25
160	166	26
167	172	27
173	179	28
180	186	29
187	192	30
193	199	31
200	206	32
207	212	33
213	219	34
220	226	35

---

### Question 1: SHOES FOR KIDS

M515Q01

Marina's feet are 163 mm long. Use the table to determine which Zedland shoe size Marina should try on.

Answer: .....

### SHOES FOR KIDS SCORING 1

#### **Full credit**

Code 1: 26.

#### **No credit**

Code 0: Other responses.

Code 9: Missing.

## M520: Skateboard

---

Eric is a great skateboard fan. He visits a shop named SKATERS to check some prices.

At this shop you can buy a complete board. Or you can buy a deck, a set of 4 wheels, a set of 2 trucks and a set of hardware, and assemble your own board.

The prices for the shop's products are:

Product	Price in zeds	
Complete skateboard	82 or 84	
Deck	40, 60 or 65	
One set of 4 Wheels	14 or 36	
One set of 2 Trucks	16	
One set of hardware (bearings, rubber pads, bolts and nuts)	10 or 20	

---

**Question 1: SKATEBOARD**

M520Q01a

M520Q01b

Eric wants to assemble his own skateboard. What is the minimum price and the maximum price in this shop for self-assembled skateboards?

(a) Minimum price: .....zeds.

(b) Maximum price: .....zeds.

**SKATEBOARD SCORING 1*****Full credit***

Code 21: Both the minimum (80) and the maximum (137) correct.

***Partial credit***

Code 11: Only the minimum (80) correct.

Code 12: Only the maximum (137) correct.

***No credit***

Code 00: Other responses.

Code 99: Missing.

---

**Question 2: SKATEBOARD**

M520Q02

The shop offers three different decks, two different sets of wheels and two different sets of hardware. There is only one choice for a set of trucks.

How many different skateboards can Eric construct?

- A 6
- B 8
- C 10
- D 12

**SKATEBOARD SCORING 2*****Full credit***

Code 1: D. 12.

**No credit**

Code 0: Other responses.

Code 9: Missing.

---

**Question 3: SKATEBOARD**

M520Q03

Eric has 120 zeds to spend and wants to buy the most expensive skateboard he can afford.

How much money can Eric afford to spend on each of the 4 parts? Put your answer in the table below.

Part	Amount (zeds)
Deck	
Wheels	
Trucks	
Hardware	

**SKATEBOARD SCORING 3**

**Full credit**

Code 1: 65 zeds on a deck, 14 on wheels, 16 on trucks and 20 on hardware.

**No credit**

Code 0: Other responses.

Code 9: Missing.

## M521: Table Tennis Tournament



### Question 1: TABLE TENNIS TOURNAMENT

M521Q01 - 0 1 9

Teun, Riek, Bep and Dirk have formed a practice group in a table tennis club. Each player wishes to play against each other player once. They have reserved two practice tables for these matches.

Complete the following match schedule; by writing the names of the players playing in each match.

	Practice Table 1	Practice Table 2
<b>Round 1</b>	Teun - Riek	Bep - Dirk
<b>Round 2</b>	..... - .....	..... - .....
<b>Round 3</b>	..... - .....	..... - .....

## TABLE TENNIS TOURNAMENT SCORING 1

### *Full credit*

Code 1: Four remaining matches correctly described and distributed over rounds 2 and 3.

- E.g.

	<b>Practice Table 1</b>	<b>Practice Table 2</b>
<b>Round 1</b>	Teun - Riek	Bep - Dirk
<b>Round 2</b>	Teun - Bep	Riek – Dirk
<b>Round 3</b>	Teun - Dirk	Riek - Bep

### *No credit*

Code 0: Other responses.

Code 9: Missing.

## M523: Lighthouse

Lighthouses are towers with a light beacon on top. Lighthouses assist sea ships in finding their way at night when they are sailing close to the shore.

A lighthouse beacon sends out light flashes with a regular fixed pattern. Every lighthouse has its own pattern.

In the diagram below you see the pattern of a certain lighthouse. The light flashes alternate with dark periods.

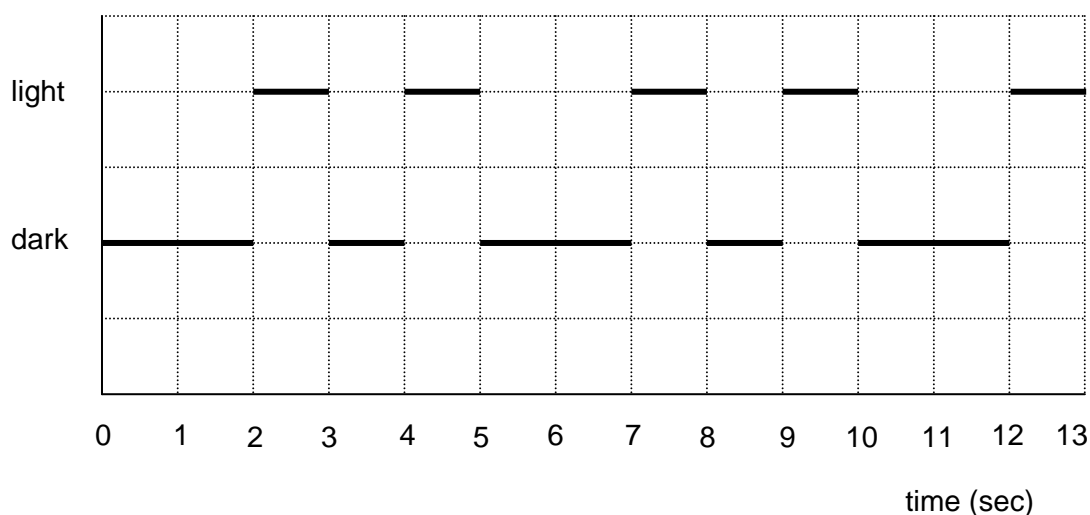

It is a regular pattern. After some time the pattern repeats itself. The time taken by one complete cycle of a pattern, before it starts to repeat, is called the *period*. When you find the period of a pattern, it is easy to extend the diagram for the next seconds or minutes or even hours.

### Question 1: LIGHTHOUSE

M523Q01

Which of the following could be the period of the pattern of this lighthouse?

- A 2 seconds.
- B 3 seconds.
- C 5 seconds.
- D 12 seconds.

### LIGHTHOUSE SCORING 1

#### **Full credit**

Code 1: C. 5 seconds.

#### **No credit**

Code 0: Other responses.

Code 9: Missing.



---

**Question 2: LIGHTHOUSE**

M523Q02

For how many seconds does the lighthouse send out light flashes in 1 minute?

- A 4
- B 12
- C 20
- D 24

**LIGHTHOUSE SCORING 2****Full credit**

Code 1: D. 24.

**No credit**

Code 0: Other responses.

Code 9: Missing.

---

**Question 3: LIGHTHOUSE**

M523Q03 - 0 1 2 9

In the diagram below, make a graph of a possible pattern of light flashes of a lighthouse that sends out light flashes for 30 seconds per minute. The period of this pattern must be equal to 6 seconds.

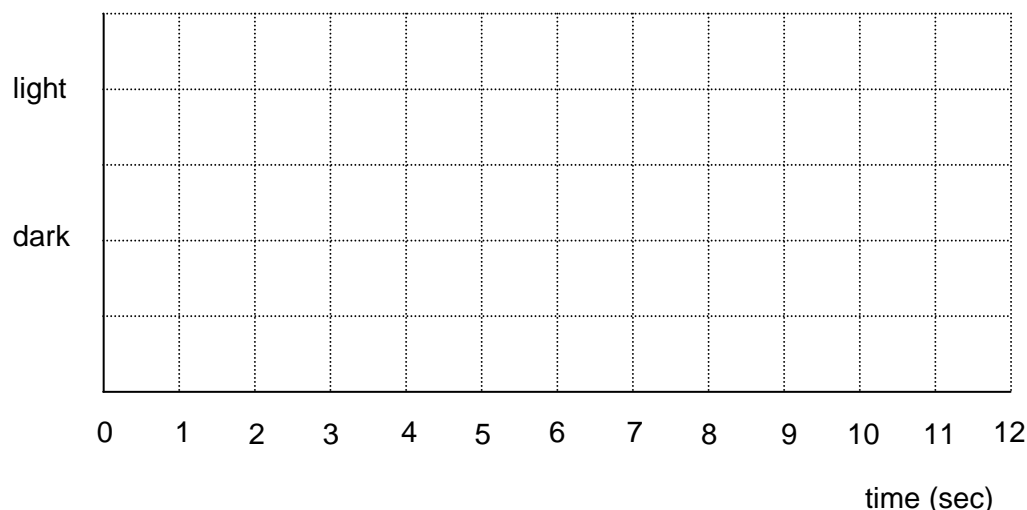
**LIGHTHOUSE SCORING 3****Full credit**

Code 2: The graph shows a pattern of light and dark with flashes for 3 seconds in every 6 seconds, and with a period of 6 seconds. This can be done in the

following ways:

- 1 one-second flash and a two-second flash (and this can be shown in several ways), or
- 1 three-second flash (which can be shown in four different ways).

If two periods are shown, the pattern must be identical for each period.

***Partial credit***

Code 1: The graph shows a pattern of light and dark with flashes for 3 seconds in every 6 seconds, but the period is not 6 seconds. If two periods are shown, the pattern must be identical for each period.

- Three one-second flashes, alternating with 3 one-second dark periods.

***No credit***

Code 0: Other responses.

Code 9: Missing.

## M525: Decreasing CO<sub>2</sub> Levels

Many scientists fear that the increasing level of CO<sub>2</sub> gas in our atmosphere is causing climate change.

The diagram below shows the CO<sub>2</sub> emission levels in 1990 (the light bars) for several countries (or regions), the emission levels in 1998 (the dark bars), and the percentage change in emission levels between 1990 and 1998 (the arrows with percentages).

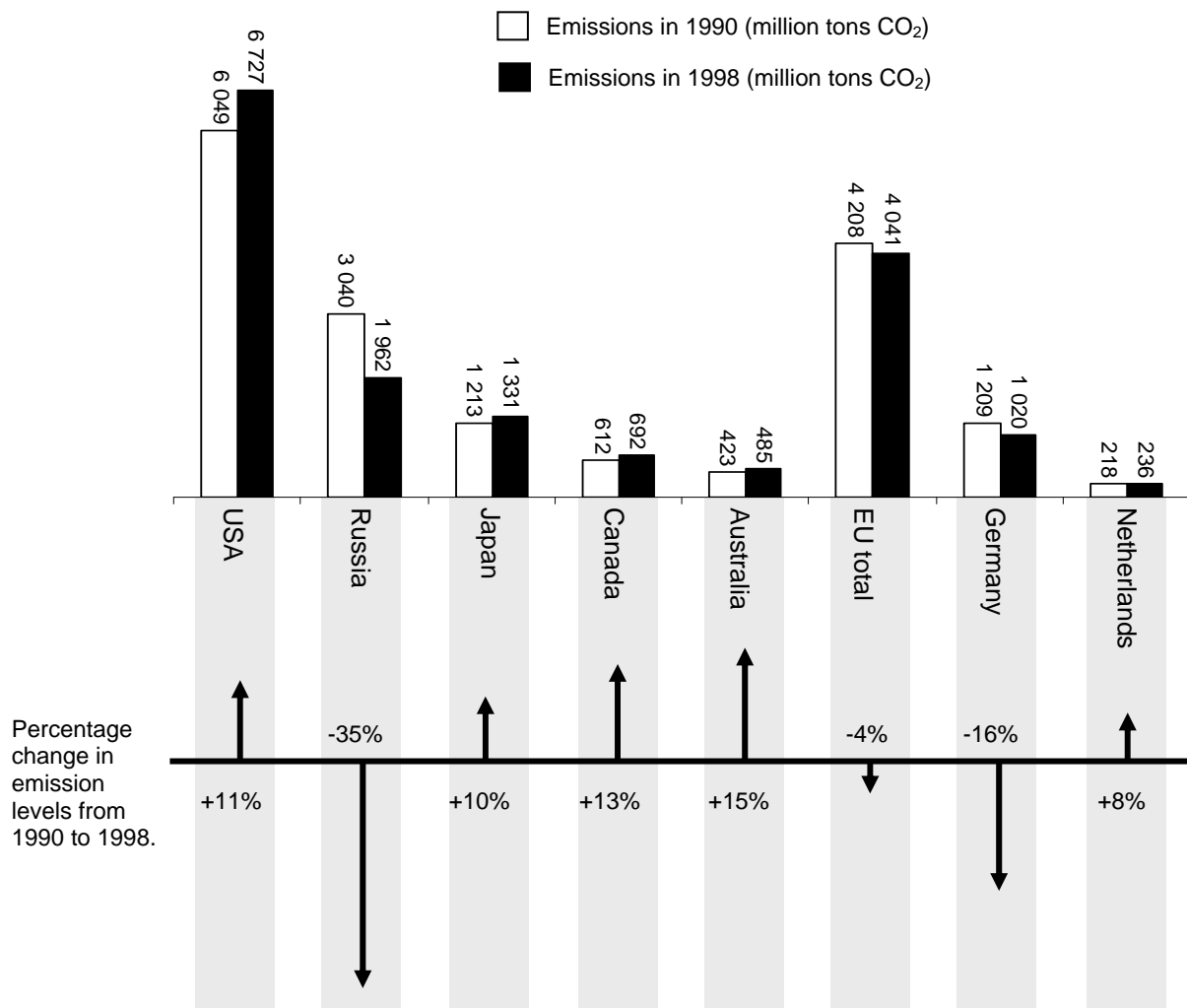

---

**Question 1: DECREASING CO<sub>2</sub> LEVELS**

M525Q01 - 0 1 2 9

In the diagram you can read that in the USA, the increase in CO<sub>2</sub> emission level from 1990 to 1998 was 11%.

Show the calculation to demonstrate how the 11% is obtained.

**DECREASING CO<sub>2</sub> LEVELS SCORING 1****Full credit**

Code 2: Correct subtraction, and correct calculation of percentage.

- $6727 - 6049 = 678$ ,  $\frac{678}{6049} \times 100\% \approx 11\%$ .

**Partial credit**

Code 1: Subtraction error and percentage calculation correct, or subtraction correct but dividing by 6727.

- $\frac{6049}{6727} \times 100 = 89.9\%$ , and  $100 - 89.9 = 10.1\%$ .

**No credit**

Code 0: Other responses, including just 'Yes' or 'No'.

- Yes, it is 11%.

Code 9: Missing.

---

**Question 2: DECREASING CO<sub>2</sub> LEVELS**

M525Q02 - 0 1 9

Mandy analysed the diagram and claimed she discovered a mistake in the percentage change in emission levels: "The percentage decrease in Germany (16%) is bigger than the percentage decrease in the whole European Union (EU total, 4%). This is not possible, since Germany is part of the EU."

Do you agree with Mandy when she says this is not possible? Give an explanation to support your answer.

**DECREASING CO<sub>2</sub> LEVELS SCORING 2****Full credit**

Code 1: No, with correct argumentation.

- No, other countries from the EU can have increases e.g. the Netherlands so the total decrease in the EU can be smaller than the decrease in Germany.

**No credit**

Code 0: Other responses.

Code 9: Missing.

---

**Question 3: DECREASING CO<sub>2</sub> LEVELS**

M525Q03 - 0 1 2 9

Mandy and Niels discussed which country (or region) had the largest **increase** of CO<sub>2</sub> emissions.

Each came up with a different conclusion based on the diagram.

Give two possible 'correct' answers to this question, and explain how you can obtain each of these answers.

**DECREASING CO<sub>2</sub> LEVELS SCORING 3*****Full credit***

Code 2: Response identifies both mathematical approaches (the largest absolute increase and the largest relative increase), and names the USA and Australia.

- USA has the largest increase in millions of tons, and Australia has the largest increase in percentage.

***Partial credit***

Code 1: Response identifies or refers to both the largest absolute increase and the largest relative increase, but the countries are not identified, or the wrong countries are named.

- Russia had the biggest increase in the amount of CO<sub>2</sub> (1078 tons), but Australia had the biggest percentage increase (15%).

***No credit***

Code 0: Other responses.

Code 9: Missing.

## M535: Twisted Building

---

In modern architecture, buildings often have unusual shapes. The picture below shows a computer model of a 'twisted building' and a plan of the ground floor. The compass points show the orientation of the building.

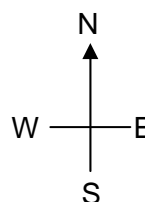
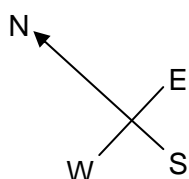
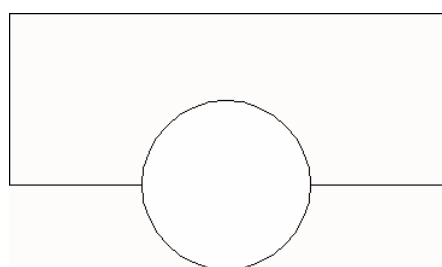
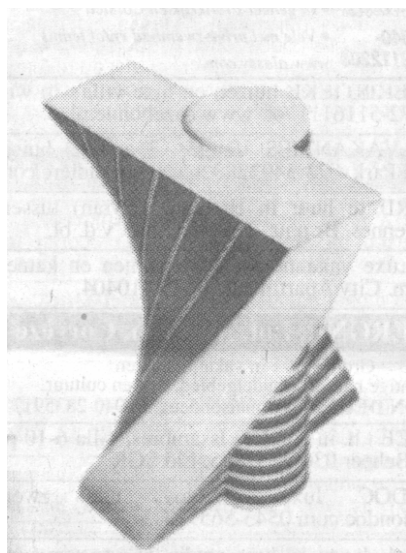

The ground floor of the building contains the main entrance and has room for shops. Above the ground floor there are 20 storeys containing apartments.

The plan of each storey is similar to the plan of the ground floor, but each has a slightly different orientation from the storey below. The cylinder contains the elevator shaft and a landing on each floor.

---

### Question 1: TWISTED BUILDING

M535Q01 - 0 1 2 9

Estimate the total height of the building, in metres. Explain how you found your answer.

#### TWISTED BUILDING SCORING 1

##### *Full credit*

Code 2: Accept answers from 50 to 90 metres if a correct explanation is given.

- One floor of the building has a height of about 2.5 meters. There is some extra room between floors. Therefore an estimate is  $21 \times 3 = 63$  metres.
- Allow 4 m for each story, so 20 of these gives 80 m, plus 10 m for the ground floor, so a total of 90 m.

**Partial credit**

Code 1: Correct calculation method and explanation, but using 20 stories instead of 21.

- Each apartment could be 3.5 metres high, 20 stories of 3.5 metres gives a total height of 70 m.

**No credit**

Code 0: Other responses, including answer without any explanation, answers with other incorrect number of floors, and answers with unreasonable estimates of the height of each floor (4 m would be the upper limit).

- Each floor is around 5 m high, so  $5 \times 21$  equals 105 metres.
- 60 m.

Code 9: Missing.

The following pictures are sideviews of the twisted building.

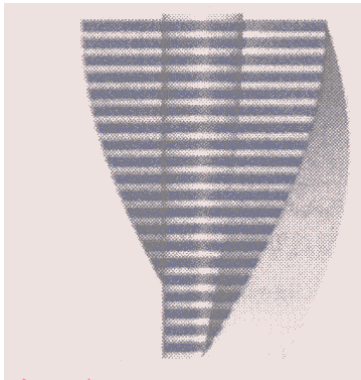

Sideview 1

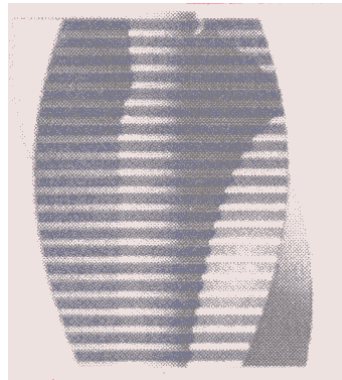

Sideview 2

---

**Question 2: TWISTED BUILDING**

M535Q02

From which direction has Sideview 1 been drawn?

- A From the North.
- B From the West.
- C From the East.
- D From the South.

**TWISTED BUILDING SCORING 2**

**Full credit**

Code 1: C. From the East.

**No credit**

Code 0: Other responses.

Code 9: Missing.

---

**Question 3: TWISTED BUILDING**

M535Q03

From which direction has Sideview **2** been drawn?

- A From the North West.
- B From the North East.
- C From the South West.
- D From the South East.

**TWISTED BUILDING SCORING 3**

**Full credit**

Code 1: D. From the South East.

**No credit**

Code 0: Other responses.

Code 9: Missing.



---

**Question 4: TWISTED BUILDING**

M535Q04 - 0 1 2 9

Each storey containing apartments has a certain 'twist' compared to the ground floor. The top floor (the 20<sup>th</sup> floor above the ground floor) is at right angles to the ground floor.

The drawing below represents the ground floor.

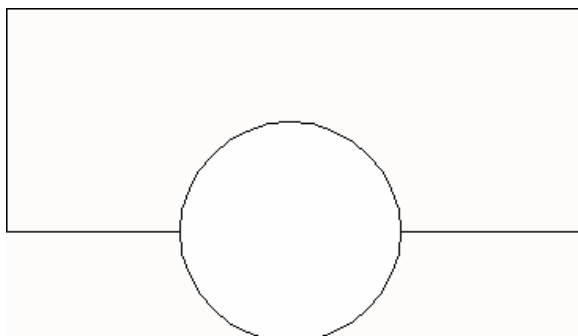

Draw in this diagram the plan of the 10<sup>th</sup> floor above the ground floor, showing how this floor is situated compared to the ground floor.

**TWISTED BUILDING SCORING 4****Full credit**

Code 2: A correct drawing, meaning correct rotation point and anti-clockwise rotation. Accept angles from 40° to 50°.

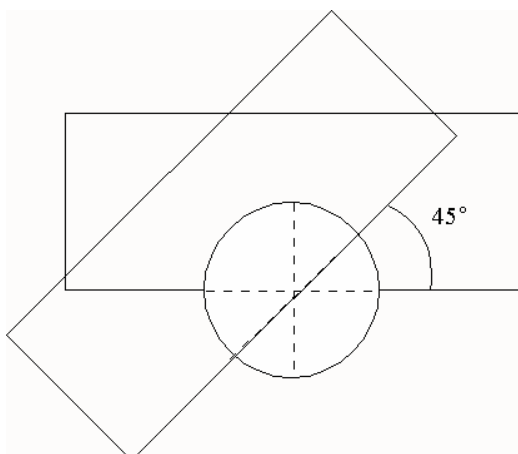
**Partial credit**

Code 1: One of the rotation angle, the rotation point, or the rotation direction incorrect.

**No credit**

Code 0: Other responses.

Code 9: Missing.

## M537: Heartbeat

---

For health reasons people should limit their efforts, for instance during sports, in order not to exceed a certain heartbeat frequency.

For years the relationship between a person's recommended maximum heart rate and the person's age was described by the following formula:

$$\text{Recommended maximum heart rate} = 220 - \text{age}$$

Recent research showed that this formula should be modified slightly. The new formula is as follows:

$$\text{Recommended maximum heart rate} = 208 - (0.7 \times \text{age})$$

---

### Question 1: HEARTBEAT

M537Q01 - 0 1 9

A newspaper article stated: "A result of using the new formula instead of the old one is that the recommended maximum number of heartbeats per minute for young people decreases slightly and for old people it increases slightly."

From which age onwards does the recommended maximum heart rate increase as a result of the introduction of the new formula? Show your work.

### HEARTBEAT SCORING 1

#### **Full credit**

Code 1: Accept 41, or 40.

- $220 - \text{age} = 208 - 0.7 \times \text{age}$  results in  $\text{age} = 40$ , so people above 40 will have a higher recommended maximum heart rate under the new formula.

#### **No credit**

Code 0: Other responses.

Code 9: Missing.

---

**Question 2: HEARTBEAT**

M537Q02 - 0 1 9

The formula *recommended maximum heart rate* =  $208 - (0.7 \times \text{age})$  is also used to determine when physical training is most effective. Research has shown that physical training is most effective when the heartbeat is at 80% of the recommended maximum heart rate.

Write down a formula for calculating the heart rate for most effective physical training, expressed in terms of age.

**HEARTBEAT SCORING 2*****Full credit***

Code 1: Any formula that is the equivalent of multiplying the formula for recommended maximum heart rate by 80%.

- heart rate =  $166 - 0.56 \times \text{age}$ .
- heart rate =  $166 - 0.6 \times \text{age}$ .
- $h = 166 - 0.56 \times a$ .
- $h = 166 - 0.6 \times a$ .
- heart rate =  $(208 - 0.7\text{age}) \times 0.8$ .

***No credit***

Code 0: Other responses.

Code 9: Missing.

## M543: Space Flight

---

Space station Mir remained in orbit for 15 years and circled Earth some 86 500 times during its time in space.

The longest stay of one cosmonaut in the Mir was around 680 days.

---

### Question 1: SPACE FLIGHT

M543Q01

Approximately how many times did this cosmonaut fly around Earth?

- A 110
- B 1 100
- C 11 000
- D 110 000

### SPACE FLIGHT SCORING 1

#### ***Full credit***

Code 1: C. 11 000.

#### ***No credit***

Code 0: Other responses.

Code 9: Missing.

## M547: Staircase

---

### Question 1: STAIRCASE

M547Q01

The diagram below illustrates a staircase with 14 steps and a total height of 252 cm:

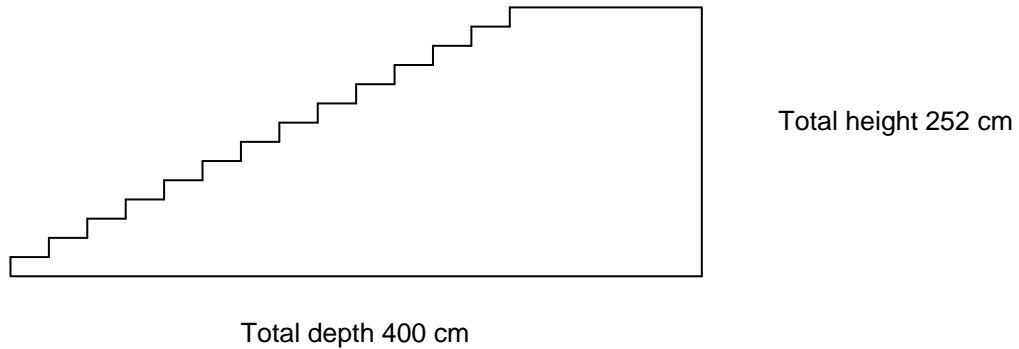

What is the height of each of the 14 steps?

Height: .....cm.

### STAIRCASE SCORING 1

#### **Full credit**

Code 1: 18.

#### **No credit**

Code 0: Other responses.

Code 9: Missing.

## M552: Rock Concert

---

### Question 1: ROCK CONCERT

M552Q01

For a rock concert a rectangular field of size 100 m by 50 m was reserved for the audience. The concert was completely sold out and the field was full with all the fans standing.

Which one of the following is likely to be the best estimate of the total number of people attending the concert?

- A 2 000
- B 5 000
- C 20 000
- D 50 000
- E 100 000

### ROCK CONCERT SCORING 1

#### **Full credit**

Code 1: C. 20 000.

#### **No credit**

Code 0: Other responses.

Code 9: Missing.

## M555: Number Cubes

### Question 2: NUMBER CUBES

M555Q02

On the right, there is a picture of two dice.

Dice are special number cubes for which the following rule applies:

The total number of dots on two opposite faces is always seven.

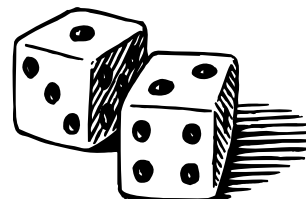

You can make a simple number cube by cutting, folding and gluing cardboard. This can be done in many ways. In the figure below you can see four cuttings that can be used to make cubes, with dots on the sides.

Which of the following shapes can be folded together to form a cube that obeys the rule that the sum of opposite faces is 7? For each shape, circle either “Yes” or “No” in the table below.

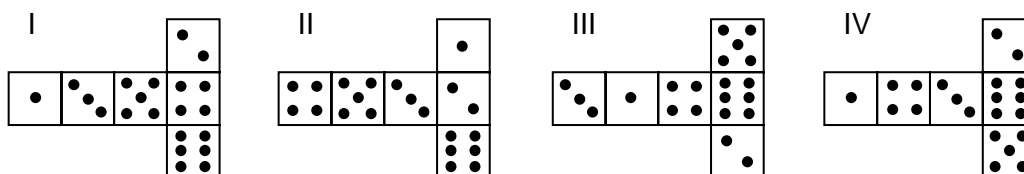

Shape	Obeys the rule that the sum of opposite faces is 7?
I	Yes / No
II	Yes / No
III	Yes / No
IV	Yes / No

### NUMBER CUBES SCORING 2

#### **Full credit**

Code 1: No, Yes, Yes, No, in that order.

#### **No credit**

Code 0: Other responses.

Code 9: Missing.

## M702: Support for the President

---

### Question 1: SUPPORT FOR THE PRESIDENT

M702Q01 - 0 1 2 9

In Zedland, opinion polls were conducted to find out the level of support for the President in the forthcoming election. Four newspaper publishers did separate nationwide polls. The results for the four newspaper polls are shown below:

Newspaper 1: 36.5% (poll conducted on January 6, with a sample of 500 randomly selected citizens with voting rights)

Newspaper 2: 41.0% (poll conducted on January 20, with a sample of 500 randomly selected citizens with voting rights)

Newspaper 3: 39.0% (poll conducted on January 20, with a sample of 1000 randomly selected citizens with voting rights)

Newspaper 4: 44.5% (poll conducted on January 20, with 1000 readers phoning in to vote).

Which newspaper's result is likely to be the best for predicting the level of support for the President if the election is held on January 25? Give two reasons to support your answer.

### SUPPORT FOR THE PRESIDENT SCORING 1

#### *Full credit*

Code 2: Newspaper 3. The poll is more recent, with larger sample size, a random selection of the sample, and only voters were asked. (Give at least two reasons). Additional information (including irrelevant or incorrect information) should be ignored.

- Newspaper 3, because they have selected more citizens randomly with voting rights.
- Newspaper 3 because it has asked 1000 people, randomly selected, and the date is closer to the election date so the voters have less time to change their mind.
- Newspaper 3 because they were randomly selected and they had voting rights.
- Newspaper 3 because it surveyed more people closer to the date.
- Newspaper 3 because the 1000 people were randomly selected.

#### *Partial credit*

Code 1: Newspaper 3, with only one reason, or without explanation.

- Newspaper 3, because the poll is closer to election date.
- Newspaper 3, because more people were surveyed than newspapers 1 and 2.
- Newspaper 3.



**No credit**

Code 0: Other responses.

- Newspaper 4. More people means more accurate results, and people phoning in will have considered their vote better.

Code 9: Missing.

# M703: Moving Walkways

## Question 1: MOVING WALKWAYS

M703Q01 - 0 1 9

On the right is a photograph of moving walkways.



The following Distance-Time graph shows a comparison between “walking on the moving walkway” and “walking on the ground next to the moving walkway.”

Distance from the start of the moving walkway

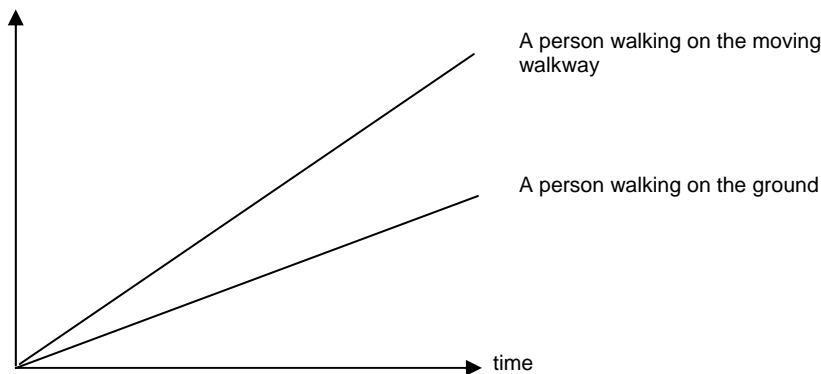

Assuming that, in the above graph, the walking pace is about the same for both persons, add a line to the graph that would represent the distance versus time for a person who is standing still on the moving walkway.

## MOVING WALKWAYS SCORING 1

### Full credit

Code 1: Accept a line below the two lines, but it must be closer to the line of “A person walking on the ground” than to the baseline.

Distance from the start of the moving walkway

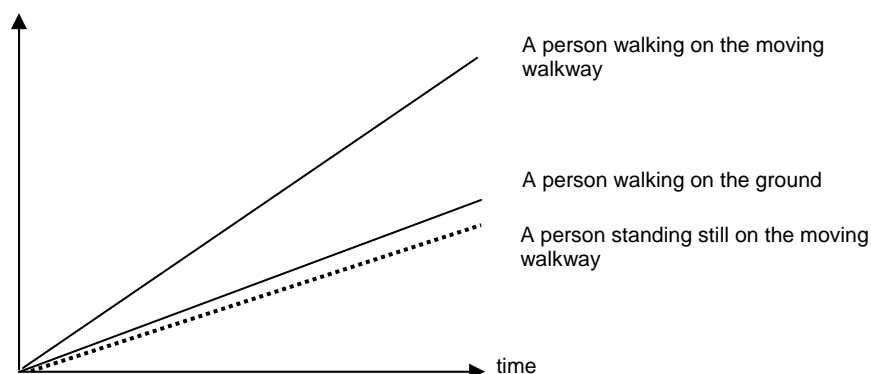

***No credit***

Code 0: Other responses.

Code 9: Missing.

## M704: The Best Car

---

A car magazine uses a rating system to evaluate new cars, and gives the award of “The Car of the Year” to the car with the highest total score. Five new cars are being evaluated, and their ratings are shown in the table.

Car	Safety Features (S)	Fuel Efficiency (F)	External Appearance (E)	Internal Fittings (T)
Ca	3	1	2	3
M2	2	2	2	2
Sp	3	1	3	2
N1	1	3	3	3
KK	3	2	3	2

The ratings are interpreted as follows:

- 3 points = Excellent
- 2 points = Good
- 1 point = Fair

---

### Question 1: THE BEST CAR

M704Q01

To calculate the total score for a car, the car magazine uses the following rule, which is a weighted sum of the individual score points:

$$\text{Total Score} = (3 \times S) + F + E + T$$

Calculate the total score for Car “Ca”. Write your answer in the space below.

Total score for “Ca”: .....

### THE BEST CAR SCORING 1

#### **Full credit**

Code 1: 15 points.

#### **No credit**

Code 0: Other responses.

Code 9: Missing.

---

**Question 2: THE BEST CAR**

M704Q02

The manufacturer of car “Ca” thought the rule for the total score was unfair.

Write down a rule for calculating the total score so that Car “Ca” will be the winner.

Your rule should include all four of the variables, and you should write down your rule by filling in positive numbers in the four spaces in the equation below.

Total score = ..... × S + ..... × F + ..... × E + ..... × T.

**THE BEST CAR SCORING 2*****Full credit***

Code 1: Correct rule that will make “Ca” the winner.

***No credit***

Code 0: Other responses.

Code 9: Missing.

## M806: Step Pattern

---

### Question 1: STEP PATTERN

M806Q01

Robert builds a step pattern using squares. Here are the stages he follows.

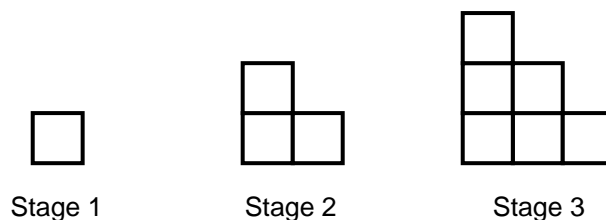

As you can see, he uses one square for Stage 1, three squares for Stage 2 and six for Stage 3.

How many squares should he use for the fourth stage?

Answer: .....squares.

### STEP PATTERN SCORING 1

#### **Full credit**

Code 1: 10.

#### **No credit**

Code 0: Other responses.

Code 9: Missing.

## M836: Postal Charges

The postal charges in Zedland are based on the weight of the items (to the nearest gram), as shown in the table below:

Weight (to nearest gram)	Charge
Up to 20 g	0.46 zeds
21 g – 50 g	0.69 zeds
51 g – 100 g	1.02 zeds
101 g – 200 g	1.75 zeds
201 g – 350 g	2.13 zeds
351 g – 500 g	2.44 zeds
501 g – 1000 g	3.20 zeds
1001 g – 2000 g	4.27 zeds
2001 g – 3000 g	5.03 zeds

### Question 1: POSTAL CHARGES

M836Q01

Which one of the following graphs is the best representation of the postal charges in Zedland? (The horizontal axis shows the weight in grams, and the vertical axis shows the charge in zeds.)

A

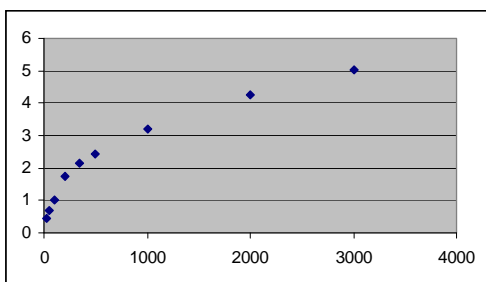

B

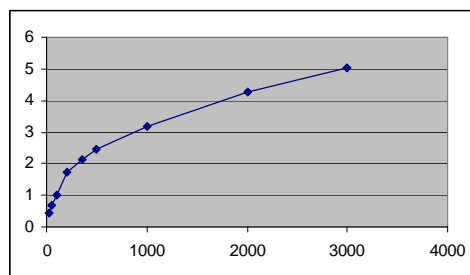

C

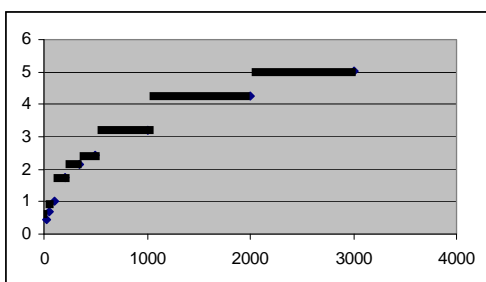

D

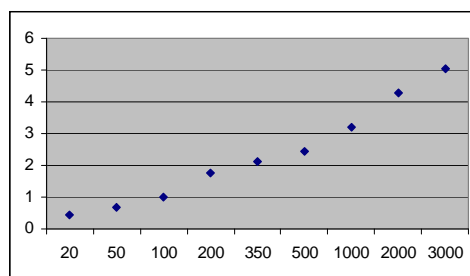

## POSTAL CHARGES SCORING 1

### ***Full credit***

Code 1: C.

### ***No credit***

Code 0: Other responses.

Code 9: Missing.

---

## Question 2: POSTAL CHARGES

M836Q02 - 0 1 9

Jan wants to send two items, weighing 40 grams and 80 grams respectively, to a friend.

According to the postal charges in Zedland, decide whether it is cheaper to send the two items as one parcel, or send the items as two separate parcels. Show your calculations of the cost in each case.

## POSTAL CHARGES SCORING 2

### ***Full credit***

Code 1: It will be cheaper to send the items as two separate parcels. The cost will be 1.71 zeds for two separate parcels, and 1.75 zeds for one single parcel containing both items.

### ***No credit***

Code 0: Other responses.

Code 9: Missing.



## Source Publications for Released Items

**OECD Sources** (available [www.pisa.oecd.org](http://www.pisa.oecd.org))

### Test Questions

- (1) Interactive Web examples: <http://pisa-sq.acer.edu.au>
- (2) PISA 2003 sample question files: <http://www.pisa.oecd.org>  
Follow the links: What PISA Produces > PISA 2003 > Test questions

### Publications

- (3) **OECD (Organisation for Economic Co-operation and Development)** (2002), *Sample Tasks from the PISA 2000 Assessment: Reading, Mathematical and Scientific Literacy*, OECD, Paris.
- (4) **OECD** (2000), *Measuring Student Knowledge and Skills - The PISA 2000 Assessment of Reading, Mathematical and Scientific Literacy*, OECD, Paris.
- (5) **OECD** (2003), *The PISA 2003 Assessment Framework - Mathematics, Reading, Science and Problem Solving Knowledge and Skills*, OECD, Paris.

Code	<u>Unit</u>		<u>Source</u>			
	Title	(1) Interactive Web Examples	(2) PISA 2003 Web Samples	(3) PISA 2000 Sample Tasks	(4) PISA 2000 Measuring Student K&S	(5) PISA 2003 Assessment Framework
M037	Farms	<input type="checkbox"/>	<input type="checkbox"/>	<input checked="" type="checkbox"/>	<input type="checkbox"/>	<input type="checkbox"/>
M047	Lichen	<input checked="" type="checkbox"/>	<input type="checkbox"/>	<input type="checkbox"/>	<input checked="" type="checkbox"/>	<input type="checkbox"/>
M124	Walking	<input type="checkbox"/>	<input checked="" type="checkbox"/>	<input type="checkbox"/>	<input type="checkbox"/>	<input type="checkbox"/>
M136	Apples	<input type="checkbox"/>	<input type="checkbox"/>	<input checked="" type="checkbox"/>	<input type="checkbox"/>	<input type="checkbox"/>
M143	Coins	<input checked="" type="checkbox"/>	<input type="checkbox"/>	<input type="checkbox"/>	<input checked="" type="checkbox"/>	<input type="checkbox"/>
M143	Cubes	<input type="checkbox"/>	<input checked="" type="checkbox"/>	<input type="checkbox"/>	<input type="checkbox"/>	<input type="checkbox"/>
M148	Continent Area	<input type="checkbox"/>	<input type="checkbox"/>	<input checked="" type="checkbox"/>	<input type="checkbox"/>	<input type="checkbox"/>
M150	Growing Up	<input type="checkbox"/>	<input checked="" type="checkbox"/>	<input type="checkbox"/>	<input type="checkbox"/>	<input type="checkbox"/>
M154	Pizzas	<input checked="" type="checkbox"/>	<input type="checkbox"/>	<input type="checkbox"/>	<input checked="" type="checkbox"/>	<input type="checkbox"/>
M158	Shapes	<input checked="" type="checkbox"/>	<input type="checkbox"/>	<input type="checkbox"/>	<input checked="" type="checkbox"/>	<input type="checkbox"/>
M159	Speed of Racing Car	<input type="checkbox"/>	<input type="checkbox"/>	<input checked="" type="checkbox"/>	<input type="checkbox"/>	<input type="checkbox"/>
M161	Triangles	<input type="checkbox"/>	<input type="checkbox"/>	<input checked="" type="checkbox"/>	<input type="checkbox"/>	<input type="checkbox"/>
M179	Robberies	<input type="checkbox"/>	<input checked="" type="checkbox"/>	<input type="checkbox"/>	<input type="checkbox"/>	<input type="checkbox"/>
M215	Braking	<input checked="" type="checkbox"/>	<input type="checkbox"/>	<input type="checkbox"/>	<input checked="" type="checkbox"/>	<input type="checkbox"/>
M266	Carpenter	<input type="checkbox"/>	<input checked="" type="checkbox"/>	<input type="checkbox"/>	<input type="checkbox"/>	<input type="checkbox"/>
M267	Patio	<input checked="" type="checkbox"/>	<input type="checkbox"/>	<input type="checkbox"/>	<input checked="" type="checkbox"/>	<input type="checkbox"/>
M307	Drug Concentrations	<input type="checkbox"/>	<input type="checkbox"/>	<input type="checkbox"/>	<input type="checkbox"/>	<input checked="" type="checkbox"/>
M309	Building Blocks	<input type="checkbox"/>	<input type="checkbox"/>	<input type="checkbox"/>	<input type="checkbox"/>	<input checked="" type="checkbox"/>
M402	Internet Relay Chat	<input type="checkbox"/>	<input checked="" type="checkbox"/>	<input type="checkbox"/>	<input type="checkbox"/>	<input type="checkbox"/>
M413	Exchange Rate	<input type="checkbox"/>	<input checked="" type="checkbox"/>	<input type="checkbox"/>	<input type="checkbox"/>	<input type="checkbox"/>

Code	<u>Unit</u>		<u>Source</u>				
	Title	(1) Interactive Web Examples	(2) PISA 2003 Web Samples	(3) PISA 2000 Sample Tasks	(4) PISA 2000 Measuring Student K&S	(5) PISA 2003 Assessment Framework	
M432	Reaction Time	<input type="checkbox"/>	<input type="checkbox"/>	<input type="checkbox"/>	<input type="checkbox"/>	<input checked="" type="checkbox"/>	
M438	Exports	<input type="checkbox"/>	<input checked="" type="checkbox"/>	<input type="checkbox"/>	<input type="checkbox"/>	<input type="checkbox"/>	
M465	Water Tank	<input type="checkbox"/>	<input type="checkbox"/>	<input type="checkbox"/>	<input type="checkbox"/>	<input checked="" type="checkbox"/>	
M467	Coloured Candies	<input type="checkbox"/>	<input checked="" type="checkbox"/>	<input type="checkbox"/>	<input type="checkbox"/>	<input type="checkbox"/>	
M468	Science Tests	<input type="checkbox"/>	<input checked="" type="checkbox"/>	<input type="checkbox"/>	<input type="checkbox"/>	<input type="checkbox"/>	
M471	Spring Fair	<input type="checkbox"/>	<input checked="" type="checkbox"/>	<input type="checkbox"/>	<input type="checkbox"/>	<input type="checkbox"/>	
M472	Swing	<input type="checkbox"/>	<input type="checkbox"/>	<input type="checkbox"/>	<input type="checkbox"/>	<input checked="" type="checkbox"/>	
M479	Student Heights	<input type="checkbox"/>	<input type="checkbox"/>	<input type="checkbox"/>	<input type="checkbox"/>	<input checked="" type="checkbox"/>	
M480	Payments by Area	<input type="checkbox"/>	<input type="checkbox"/>	<input type="checkbox"/>	<input type="checkbox"/>	<input checked="" type="checkbox"/>	
M484	Bookshelves	<input type="checkbox"/>	<input checked="" type="checkbox"/>	<input type="checkbox"/>	<input type="checkbox"/>	<input type="checkbox"/>	
M505	Litter	<input type="checkbox"/>	<input checked="" type="checkbox"/>	<input type="checkbox"/>	<input type="checkbox"/>	<input type="checkbox"/>	
M509	Earthquake	<input type="checkbox"/>	<input checked="" type="checkbox"/>	<input type="checkbox"/>	<input type="checkbox"/>	<input type="checkbox"/>	
M510	Choices	<input type="checkbox"/>	<input checked="" type="checkbox"/>	<input type="checkbox"/>	<input type="checkbox"/>	<input type="checkbox"/>	
M513	Test Scores	<input type="checkbox"/>	<input checked="" type="checkbox"/>	<input type="checkbox"/>	<input type="checkbox"/>	<input type="checkbox"/>	
M515	Shoes for Kids	<input type="checkbox"/>	<input checked="" type="checkbox"/>	<input type="checkbox"/>	<input type="checkbox"/>	<input type="checkbox"/>	
M520	Skateboard	<input type="checkbox"/>	<input checked="" type="checkbox"/>	<input type="checkbox"/>	<input type="checkbox"/>	<input type="checkbox"/>	
M521	Table Tennis Tournament	<input type="checkbox"/>	<input checked="" type="checkbox"/>	<input type="checkbox"/>	<input type="checkbox"/>	<input type="checkbox"/>	
M523	Lighthouse	<input type="checkbox"/>	<input type="checkbox"/>	<input type="checkbox"/>	<input type="checkbox"/>	<input checked="" type="checkbox"/>	
M525	Decreasing CO <sub>2</sub> Levels	<input type="checkbox"/>	<input checked="" type="checkbox"/>	<input type="checkbox"/>	<input type="checkbox"/>	<input type="checkbox"/>	
M535	Twisted Building	<input type="checkbox"/>	<input type="checkbox"/>	<input type="checkbox"/>	<input type="checkbox"/>	<input checked="" type="checkbox"/>	
M537	Heartbeat	<input type="checkbox"/>	<input type="checkbox"/>	<input type="checkbox"/>	<input type="checkbox"/>	<input checked="" type="checkbox"/>	
M543	Space Flight	<input type="checkbox"/>	<input checked="" type="checkbox"/>	<input type="checkbox"/>	<input type="checkbox"/>	<input type="checkbox"/>	
M547	Staircase	<input type="checkbox"/>	<input checked="" type="checkbox"/>	<input type="checkbox"/>	<input type="checkbox"/>	<input type="checkbox"/>	
M552	Rock Concert	<input type="checkbox"/>	<input type="checkbox"/>	<input type="checkbox"/>	<input type="checkbox"/>	<input checked="" type="checkbox"/>	
M555	Number Cubes	<input type="checkbox"/>	<input checked="" type="checkbox"/>	<input type="checkbox"/>	<input type="checkbox"/>	<input type="checkbox"/>	
M702	Support for the President	<input type="checkbox"/>	<input checked="" type="checkbox"/>	<input type="checkbox"/>	<input type="checkbox"/>	<input type="checkbox"/>	
M703	Moving Walkways	<input type="checkbox"/>	<input type="checkbox"/>	<input type="checkbox"/>	<input type="checkbox"/>	<input checked="" type="checkbox"/>	
M704	The Best Car	<input type="checkbox"/>	<input checked="" type="checkbox"/>	<input type="checkbox"/>	<input type="checkbox"/>	<input type="checkbox"/>	
M806	Step Pattern	<input type="checkbox"/>	<input checked="" type="checkbox"/>	<input type="checkbox"/>	<input type="checkbox"/>	<input type="checkbox"/>	
M836	Postal Charges	<input type="checkbox"/>	<input type="checkbox"/>	<input type="checkbox"/>	<input type="checkbox"/>	<input checked="" type="checkbox"/>	